

|| DATE: 04-05-2025 ||

Important Instructions:

1. The test is of **3 hours** duration and the Test Booklet contains **180** multiple-choice questions (four options with a single correct answer) from **Physics, Chemistry, and Biology (Botany and Zoology)**. All questions are compulsory.
2. Each question carries **4 marks**. For **each correct response**, the candidate will get **4 marks**. For **each incorrect response, 1 mark will be deducted** from the total scores. The maximum mark is **720**.
3. Use a **Blue/Black** ballpoint Pen only for writing particulars on this page/markings responses on the Answer Sheet.
4. Rough work is to be done in the space provided for this purpose in the Test Booklet only.
5. On completion of the test, the candidate **must hand over the Answer Sheet (ORIGINAL and OFFICE Copy)** to the **Invigilator** before leaving the room/hall. The candidates are allowed to take away this Test Booklet with them.
6. The CODE for this Booklet is **00**.
7. The candidates should ensure that the Answer Sheet is not folded. Do not make any stray marks on the Answer Sheet. Do not write your Roll No. anywhere else except in the specified space in the Test Booklet/Answer Sheet. The use of white fluid for correction is **NOT** permissible on the Answer Sheet.
8. Each candidate must show on-demand his/her Admit Card to the Invigilator.
9. No candidate, without special permission of the Centre Superintendent or Invigilator, would leave his/her seat.
10. Use of an Electronic/Manual Calculator is prohibited.
11. The candidates are governed by all Rules and Regulations of the examination with regard to their conduct in the Examination Room/Hall. All cases of unfair means will be dealt with as per Rules and Regulations of this examination.
12. No part of the Test Booklet and Answer Sheet shall be detached under any circumstances.
13. The candidates will write the Correct Test Booklet Code as given in the Test Booklet/Answer Sheet in the Attendance Sheet.

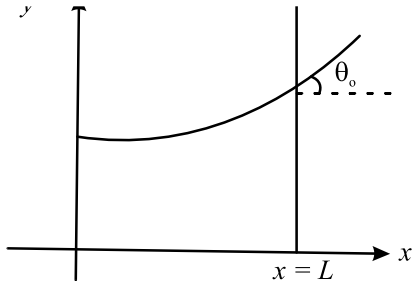

(take $\theta(x) = \sin \theta(x) = \tan \theta(x) = \frac{dy}{dx}$, g is the acceleration due to gravity)

(1) $\frac{d^2y}{dx^2} = \frac{\rho g}{S} x$ (2) $\frac{d^2y}{dx^2} = \frac{\rho g}{S} y$
 (3) $\frac{d^2y}{dx^2} = \sqrt{\frac{\rho g}{S}}$ (4) $\frac{dy}{dx} = \sqrt{\frac{\rho g}{S} x}$

2. A microscope has an objective of focal length 2 cm, eyepiece of focal length 4 cm and the tube length of 40 cm. If the distance of distinct vision of eye is 25 cm, the magnification in the microscope is
- (1) 100 (2) 125
 (3) 150 (4) 250

3. An electron (mass 9×10^{-31} kg and charge 1.6×10^{-19} C) moving with speed $c/100$ ($c =$ speed of light) is injected into a magnetic field \vec{B} of magnitude 9×10^{-4} T perpendicular to its direction of motion. We wish to apply an uniform electric \vec{E} together with the magnetic field so that the electron does not deflect from its path. Then (speed of light $c = 3 \times 10^8$ ms $^{-1}$)
- (1) \vec{E} is perpendicular to \vec{B} and its magnitude is 27×10^4 V m $^{-1}$
 (2) \vec{E} is perpendicular to \vec{B} and its magnitude is 27×10^2 V m $^{-1}$
 (3) \vec{E} is parallel to \vec{B} and its magnitude is 27×10^2 V m $^{-1}$
 (4) \vec{E} is parallel to \vec{B} and its magnitude is 27×10^4 V m $^{-1}$

4. There are two inclined surfaces of equal length (L) and same angle of inclination 45° with the horizontal. One of them is rough and the other is perfectly smooth A given body takes 2 times as

5. The kinetic energies of two similar cars A and B are 100 J and 225 J respectively. On applying breaks, car A stops after 1000 m and car B stops after 1500 m. If F_A and F_B are the forces applied by the breaks on cars A and B, respectively, then the ratio F_A/F_B is

(1) $\frac{3}{2}$ (2) $\frac{2}{3}$
 (3) $\frac{1}{3}$ (4) $\frac{1}{2}$

6. The current passing through the battery in the given circuit is:

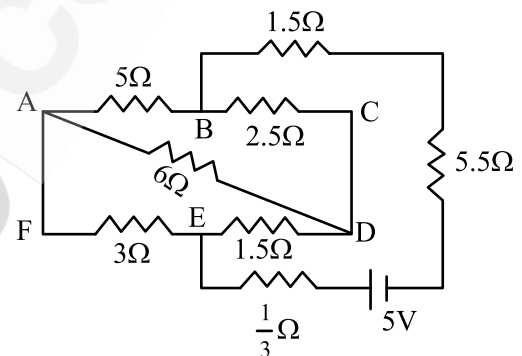

(1) 2.0 A (2) 0.5 A
 (3) 2.5 A (4) 1.5 A

7. A bob of heavy mass m is suspended by a light string of length l . The bob is given a horizontal velocity v_0 as shown in figure. If the string gets slack at some point P making an angle θ from the horizontal, the ratio of the speed v of the bob at point P to its initial speed v_0 is:

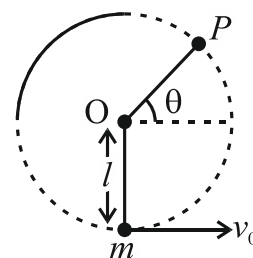

(1) $(\sin \theta)^{1/2}$ (2) $\left(\frac{1}{2+3 \sin \theta} \right)^{1/2}$
 (3) $\left(\frac{\cos \theta}{2+3 \sin \theta} \right)^{1/2}$ (4) $\left(\frac{\sin \theta}{2+3 \sin \theta} \right)^{1/2}$

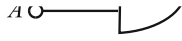

- (1) AND
- (2) NAND
- (3) OR
- (4) NOR

9. The electric field in a plane electromagnetic wave is given by

$$E_z = 60 \cos(5x + 1.5 \times 10^9 t) \text{ V/m.}$$

Then expression for the corresponding magnetic field is (here subscripts denote the direction of the field):

- (1) $B_y = 2 \times 10^{-7} \cos(5x + 1.5 \times 10^9 t) T$
- (2) $B_x = 2 \times 10^{-7} \cos(5x + 1.5 \times 10^9 t) T$
- (3) $B_z = 60 \cos(5x + 1.5 \times 10^9 t) T$
- (4) $B_y = 60 \sin(5x + 1.5 \times 10^9 t) T$

10. A ball of mass 0.5 kg is dropped from a height of 40 m. The ball hits the ground and rises to a height of 10 m. The impulse imparted to the ball during its collision with the ground is

(Take $g = 9.8 \text{ m/s}^2$)

- (1) 21 Ns
- (2) 7 Ns
- (3) 0
- (4) 84 Ns

11. AB is a part of an electrical circuit (see figure). The potential difference " $V_A - V_B$ ", at the instant when current $i = 2 \text{ A}$ and is increasing at a rate of 1 amp/second is:

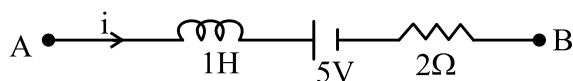

- (1) 5 volt
- (2) 6 volt
- (3) 9 volt
- (4) 10 volt

- (4) 4:1

13. In a certain camera, a combination of four similar thin convex lenses are arranged axially in contact. Then the power of the combination and the total magnification in comparison to the power (p) and magnification (m) for each lens will be, respectively—

- (1) $4p$ and $4m$
- (2) p^4 and $4m$
- (3) $4p$ and m^4
- (4) p^4 and m^4

14. An oxygen cylinder of volume 30 litre has 18.20 moles of oxygen. After some oxygen is withdrawn from the cylinder, its gauge pressure drops to 11 atmospheric pressure at temperature 27°C . The mass of the oxygen withdrawn from the cylinder is nearly equal to :

[Given, $R = \frac{100}{12} \text{ J mol}^{-1} \text{ K}^{-1}$, and molecular mass

of $\text{O}_2 = 32$, 1 atm pressure = $1.01 \times 10^5 \text{ N/m}^2$]

- (1) 0.125 kg
- (2) 0.144 kg
- (3) 0.116 kg
- (4) 0.156 kg

15. In some appropriate units, time (t) and position (x) relation of a moving particle is given by $t = x^2 + x$. The acceleration of the particle is

- (1) $-\frac{2}{(x+2)^3}$
- (2) $-\frac{2}{(2x+1)^3}$
- (3) $+\frac{2}{(x+1)^3}$
- (4) $+\frac{2}{2x+1}$

- (2) 7.8 A and 45°
 (3) 15.6 A and 30°
 (4) 15.6 A and 45°
17. The Sun rotates around its centre once in 27 days. What will be the period of revolution if the Sun were to expand to twice its present radius without any external influence? Assume the Sun to be a sphere of uniform density.
- (1) 100 days
 (2) 105 days
 (3) 115 days
 (4) 108 days
18. A model for quantized motion of an electron in a uniform magnetic field B states that the flux passing through the orbit of the electron is $n(h/e)$ where n is an integer, h is Planck's constant and e is the magnitude of electron's charge. According to the model, the magnetic moment of an electron in its lowest energy state will be (m is the mass of the electron)
- (1) $\frac{he}{\pi m}$
 (2) $\frac{he}{2\pi m}$
 (3) $\frac{heB}{\pi m}$
 (4) $\frac{heB}{2\pi m}$
19. Three identical heat conducting rods are connected in series as shown in the figure. The rods on the sides have thermal conductivity $2K$ while that in the middle has thermal conductivity K . The left end of the combination is maintained at temperature $3T$ and the right end at T . The rods are thermally insulated from outside. In steady state, temperature at the left junction is T_1 and that at the right junction is T_2 . The ratio T_1/T_2 is:
- (3) $\frac{2}{3}$ (4) $\frac{3}{4}$
20. The plates of a parallel plate capacitor are separated by d . Two slabs of different dielectric constant K_1 and K_2 with thickness $\frac{3}{8}d$ and $\frac{d}{2}$, respectively are inserted in the capacitor. Due to this, the capacitance becomes two times larger than when there is nothing between the plates. If $K_1 = 1.25 K_2$, the value of K_1 is:
- (1) 2.66
 (2) 2.33
 (3) 1.60
 (4) 1.33
21. Two cities X and Y are connected by a regular bus service with a bus leaving in either direction every T min. A girl is driving scooter with a speed of 60 km/h in the direction X to Y notices that a bus goes past her every 30 minutes in the direction of her motion, and every 10 minutes in the opposite direction. Choose the correct option for the period T of the bus service and the speed (assumed constant) of the buses.
- (1) 9 min, 40 km/h
 (2) 25 min, 100 km/h
 (3) 10 min, 90 km/h
 (4) 15 min, 120 km/h
22. A uniform rod of mass 20 kg and length 5 m leans against a smooth vertical wall making an angle of 60° with it. The other end rests on a rough horizontal floor. The friction force that the floor exerts on the rod is:
 (take $g = 10 \text{ m/s}^2$)
- (1) 100 N
 (2) $100\sqrt{3}$ N
 (3) 200 N
 (4) $200\sqrt{3}$ N

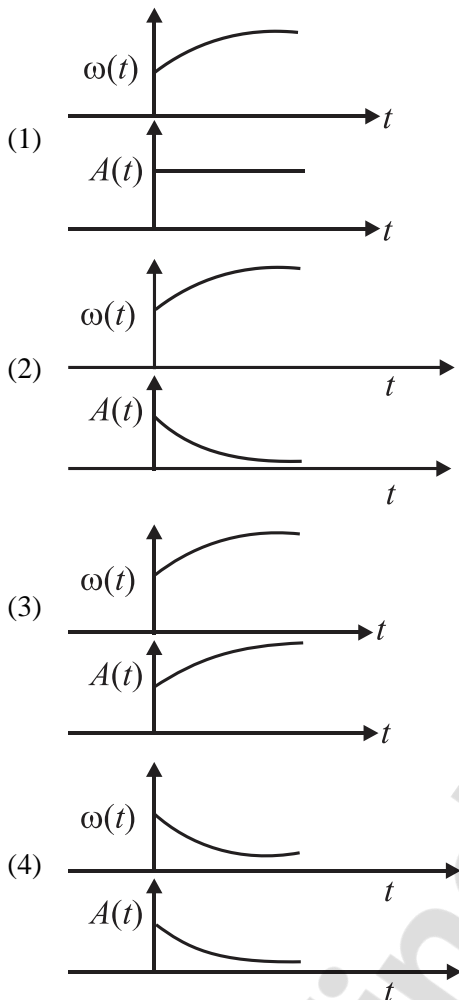

24. A balloon is made of a material of surface tension S and its inflation outlet (from where gas is filled in it) has small area A . It is filled with a gas of density ρ and takes a spherical shape of radius R . When the gas is allowed to flow freely out of it, its radius r changes from R to 0 (zero) in time T . If the speed $v(r)$ of gas coming out of the balloon depends on r as r^a and $T \propto S^\alpha A^\beta \rho^\gamma R^\delta$

- (1) $a = \frac{1}{2}, \alpha = \frac{1}{2}, \beta = -1, \gamma = +1, \delta = \frac{3}{2}$
- (2) $a = -\frac{1}{2}, \alpha = -\frac{1}{2}, \beta = -1, \gamma = -\frac{1}{2}, \delta = \frac{5}{2}$
- (3) $a = -\frac{1}{2}, \alpha = -\frac{1}{2}, \beta = -1, \gamma = \frac{1}{2}, \delta = \frac{7}{2}$
- (4) $a = \frac{1}{2}, \alpha = \frac{1}{2}, \beta = -\frac{1}{2}, \gamma = \frac{1}{2}, \delta = \frac{7}{2}$

division is 8, the measured diameter after zero error correction, is:

- (1) 5.18 cm (2) 5.08 cm
 (3) 4.98 cm (4) 5.00 cm

26. A parallel plate capacitor made of circular plates is being charged such that the surface charge density on its plates is increasing at a constant rate with time. The magnetic field arising due to displacement current is:

- (1) zero at all places
 (2) constant between the plates and zero outside the plates.
 (3) non-zero everywhere with maximum at the imaginary cylindrical surface connecting peripheries of the plates.
 (4) zero between the plates and non-zero outside.

27. An unpolarized light beam travelling in air is incident on a medium of refractive index 1.73 at Brewster's angle. Then-

- (1) reflected light is completely polarized and the angle of reflection is close to 60°
 (2) reflected light is partially polarized and the angle of reflection is close to 30° .
 (3) both reflected and transmitted light are perfectly polarized with angles of reflection and refraction close to 60° and 30° , respectively.
 (4) transmitted light is completely polarized with angle of refraction close to 30°

28. Two identical charged conducting spheres A and B have their centres separated by a certain distance. Charge on each sphere is q and the force of repulsion between them is F . A third identical uncharged conducting sphere is brought in contact with sphere A first and then with B and finally removed from both. New force of repulsion between spheres A and B (Radii of A and B are negligible compared to the distance of separation so that for calculating force between them they can be considered as point charges) is best given as:

- (1) $\frac{3F}{5}$ (2) $\frac{2F}{3}$
 (3) $\frac{F}{2}$ (4) $\frac{3F}{8}$

- (1) 1.3 atm
- (2) 1.6 atm
- (3) 1.4 atm
- (4) 1.8 atm

30. A particle of mass m is moving around the origin with a constant force F pulling it towards the origin. If Bohr model is used to describe its motion, the radius r of the n^{th} orbit and the particle's speed v in the orbit depend on n as

- (1) $r \propto n^{1/3}; v \propto n^{1/3}$
- (2) $r \propto n^{1/3}; v \propto n^{2/3}$
- (3) $r \propto n^{2/3}; v \propto n^{1/3}$
- (4) $r \propto n^{4/3}; v \propto n^{-1/3}$

31. The radius of Martian orbit around the Sun is about 4 times the radius of the orbit of Mercury. The Martian year is 687 Earth days. Then which of the following is the length of 1 year on Mercury?

- (1) 88 earth days
- (2) 225 earth days
- (3) 172 earth days
- (4) 124 earth days

32. A body weight 48 N on the surface of the earth. The gravitational force experienced by the body due to the earth at a height equal to one-third the radius of the earth from its surface is:

- (1) 16 N
- (2) 27 N
- (3) 32 N
- (4) 36 N

33. A wire of resistance R is cut into 8 equal pieces. From these pieces two equivalent resistances are made by adding four of these together in parallel. Then these two sets are added in series. The net effective resistance of the combination is:

(Given Bohr radius = 0.052 nm)

- (1) 0.067 nm
- (2) 0.67 nm
- (3) 1.67 nm
- (4) 2.67 nm

35. An electric dipole with dipole moment $5 \times 10^{-6} \text{ Cm}$ is aligned with the direction of a uniform electric field of magnitude $4 \times 10^5 \text{ N/C}$. The dipole is then rotated through an angle of 60° with respect to the electric field. The change in the potential energy of the dipole is:

- (1) 0.8 J
- (2) 1.0 J
- (3) 1.2 J
- (4) 1.5 J

36. A constant voltage of 50 V is maintained between the points A and B of the circuit shown in the figure. The current through the branch CD of the circuit is:

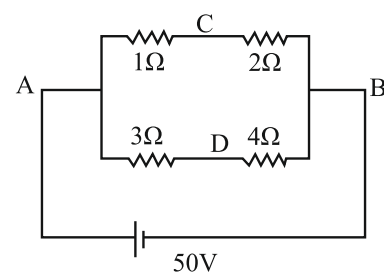

- (1) 1.5 A
- (2) 2.0 A
- (3) 2.5 A
- (4) 3.0 A

37. A photon and an electron (mass m) have the same energy E . The ratio $(\lambda_{\text{photon}}/\lambda_{\text{electron}})$ of their de Broglie wavelengths is (c is the speed of light)

- (1) $\sqrt{E/2m}$
- (2) $c\sqrt{2mE}$
- (3) $c\sqrt{\frac{2m}{E}}$
- (4) $\frac{1}{c}\sqrt{E/2m}$

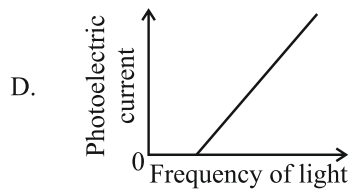
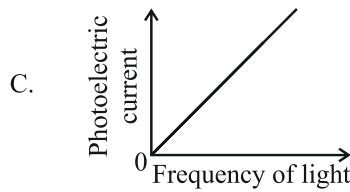
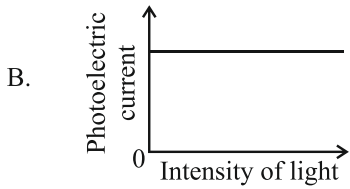

- (1) A only (2) A and C
 (3) A and D (4) B and D

39. A sphere of radius R is cut from a larger solid sphere of radius $2R$ as shown in the figure. The ratio of the moment of inertia of the smaller sphere to that of the rest part of the sphere about the Y-axis is:

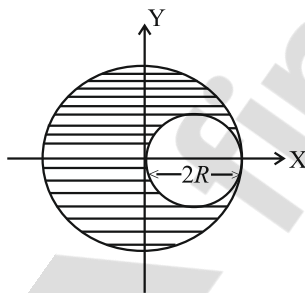

- (1) $\frac{7}{8}$ (2) $\frac{7}{40}$
 (3) $\frac{7}{57}$ (4) $\frac{7}{64}$

40. A full wave rectifier circuit with diodes (D_1) and (D_2) is shown in the figure. If input supply voltage $V_{in} = 220\sin(100\pi t)$ volt, then at $t = 15$ m sec

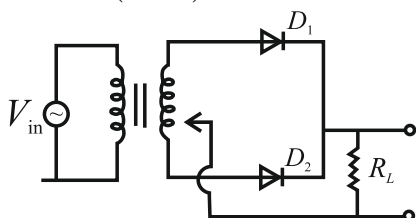

pressure, the pistons of gas A and B are displaced by 16 cm and 9 cm, respectively. If the change in their internal energy is the same, then the ratio r_A/r_B is equal to

- (1) $\frac{4}{3}$ (2) $\frac{3}{4}$
 (3) $\frac{2}{\sqrt{3}}$ (4) $\frac{\sqrt{3}}{2}$

42. A physical quantity P is related to four observations a, b, c and d as follows:

$$P = a^3 b^2 / c \sqrt{d}$$

The percentage errors of measurement in a, b, c and d are 1%, 3%, 2%, and 4% respectively. The percentage error in the quantity P is

- (1) 10% (2) 2%
 (3) 13% (4) 15%

43. The intensity of transmitted light when a polaroid sheet, placed between two crossed polarization at 22.5° from the polarization axis of one of the polaroid, is (I_0 is the intensity of polarised light after passing through the first polaroid):

- (1) $\frac{I_0}{2}$ (2) $\frac{I_0}{4}$
 (3) $\frac{I_0}{8}$ (4) $\frac{I_0}{16}$

44. Two identical point masses P and Q , suspended from two separate massless springs of spring constants k_1 and k_2 respectively, oscillate vertically. If their maximum speeds are the same, the ratio (A_Q/A_P) of the amplitude A_Q of mass Q to the amplitude A_P of mass P is:

- (1) $\frac{k_2}{k_1}$ (2) $\frac{k_1}{k_2}$
 (3) $\sqrt{\frac{k_2}{k_1}}$ (4) $\sqrt{\frac{k_1}{k_2}}$

45. A pipe open at both ends has a fundamental frequency f in air. The pipe is now dipped vertically in a water drum to half of its length. The fundamental frequency of the air column is now equal to:

- (1) $\frac{f}{2}$ (2) f
 (3) $\frac{3f}{2}$ (4) $2f$

(2) $\frac{1}{16}$

(3) $\frac{1}{9}$

(4) $\frac{1}{4}$

47. Which of the following statements are true?
- Unlike Ga that has a very high melting point, Cs has a very low melting point.
 - On Pauling scale, the electronegativity values of N and Cl are not the same.
 - Ar, K^+ , Cl^- , Ca^{2+} and S^{2-} are all isoelectronic species.
 - The correct order of the first ionization enthalpies of Na, Mg, Al, and Si is $Si > Al > Mg > Na$.
 - The atomic radius of Cs is greater than that of Li and Rb.

Choose the **correct** answer from the options given below:

- A, B and E only
- C and E only
- C and D only
- A, C and E only

48. Match List-I with List-II.

List-I (Ion)	List-II (Group Number in Cation Analysis)
A. Co^{2+}	I. Group-I
B. Mg^{2+}	II. Group-III
C. Pb^{2+}	III. Group-IV
D. Al^{3+}	IV. Group-VI

Choose the **correct** answer from the options given below:

- A-III, B-IV, C-II, D-I
- A-III, B-IV, C-I, D-II
- A-III, B-II, C-IV, D-I
- A-III, B-II, C-I, D-IV

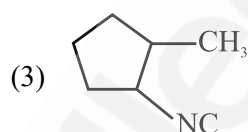
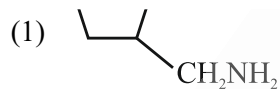

50. Energy and radius of first Bohr orbit of He^+ and Li^{2+} are [Given $R_H = 2.18 \times 10^{-18}$ J, $a_0 = 52.9$ pm]

(1) $E_n(Li^{2+}) = -19.62 \times 10^{-18}$ J;

$r_n(Li^{2+}) = 17.6$ pm

$E_n(He^+) = -8.72 \times 10^{-18}$ J;

$r_n(He^+) = 26.4$ pm

(2) $E_n(Li^{2+}) = -8.72 \times 10^{-18}$ J;

$r_n(Li^{2+}) = 26.4$ pm

$E_n(He^+) = -19.62 \times 10^{-18}$ J;

$r_n(He^+) = 17.6$ pm

(3) $E_n(Li^{2+}) = -19.62 \times 10^{-16}$ J;

$r_n(Li^{2+}) = 17.6$ pm

$E_n(He^+) = -8.72 \times 10^{-16}$ J;

$r_n(He^+) = 26.4$ pm

(4) $E_n(Li^{2+}) = -8.72 \times 10^{-16}$ J;

$r_n(Li^{2+}) = 17.6$ pm

$E_n(He^{2+}) = -19.62 \times 10^{-16}$ J;

$r_n(He^+) = 17.6$ pm

51. Which of the following are paramagnetic?

- $[NiCl_4]^{2-}$
- $Ni(CO)_4$
- $[Ni(CN)_4]^{2-}$
- $[Ni(H_2O)_6]^{2+}$
- $Ni(PPh_3)_4$

Choose the **correct** answer from the options given below:

- A and C only
- B and E only
- A and D only
- A, D and E only

- (2) Both Statement I and Statement II are incorrect.
 (3) Statement I is correct but Statement II is incorrect.
 (4) Statement I is incorrect but Statement II is correct.

53. Which among the following electronic configurations belong to main group elements?

- A. [Ne]3s¹ B. [Ar]3d³ 4s²
 C. [Kr]4d¹⁰5s²5p⁵ D. [Ar]3d¹⁰4s¹
 E. [Rn]5f⁹6d²7s²

Choose the **correct** answer from the options given below:

- (1) B and E only
 (2) A and C only
 (3) D and E only
 (4) A, C and D only

54. Dalton's Atomic theory could not explain which of the following?

- (1) Law of conservation of mass
 (2) Law of constant proportion
 (3) Law of multiple proportion
 (4) Law of gaseous volume

55. Consider the following compounds:

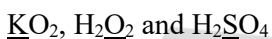

The oxidation states of the underlined elements in them are, respectively,

- (1) +1, -1, and +6
 (2) +2, -2, and +6
 (3) +1, -2, and +4
 (4) +4, -4, and +6

56. If the half-life (t_{1/2}) for a first order reaction is 1 minute, then the time required for 99.9% completion of the reaction is closet to:

- (1) 2 minutes (2) 4 minutes
 (3) 5 minutes (4) 10 minutes

- (3) C < D < A < B (4) C < A < D < B

58. Which one of the following compounds can exist as cis-trans isomers?

- (1) Pent-1-ene
 (2) 2-Methylhex-2-ene
 (3) 1,1-Dimethylcyclopropane
 (4) 1,2-Dimethylcyclohexane

59. Phosphoric acid ionizes in three steps with their ionization constant values K_{a1}, K_{a2} and K_{a3}, respectively, while K is the overall ionization constant. Which of the following statements are true?

- A. $\log K = \log K_{a_1} + \log K_{a_2} + \log K_{a_3}$
 B. H₃PO₄ is stronger acid than H₂PO₄⁻ and HPO₄²⁻.
 C. K_{a1} > K_{a2} > K_{a3}
 D. $K_{a_1} = \frac{K_{a_3} + K_{a_2}}{2}$

Choose the **correct** answer from the options given below:

- (1) A and B only (2) A and C only
 (3) B, C and D only (4) A, B and C only

60. Which one of the following reactions does NOT give benzene as the product?

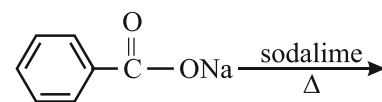
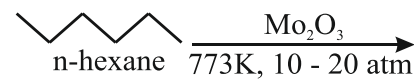
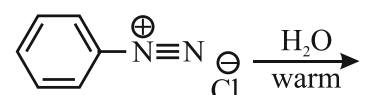
- (1)  $\xrightarrow[\Delta]{\text{sodalime}}$
- (2)  $\xrightarrow[773\text{K}, 10-20\text{ atm.}]{\text{Mo}_2\text{O}_3}$
- (3) $\text{H}-\text{C}\equiv\text{C}-\text{H} \xrightarrow[\text{at } 873\text{ K}]{\text{red hot Iron Tube}}$
- (4)  $\xrightarrow[\text{warm}]{\text{H}_2\text{O}}$

- (2) 0.125
 (3) 0.225
 (4) 0.215

62. Given below are two statements:

Statement I: A hypothetical diatomic molecule with bond order zero is quite stable.

Statement II: As bond order increases, the bond length increases.

In the light of the above statements, chose the **most appropriate** answer from the options given below:

- (1) Both statement I and Statement II are true
 (2) Both statement I and Statement II are false
 (3) Statement I is true but Statement II is false
 (4) Statement I is true but Statement II is true

63. Out of the following complex compounds, which of the compound will be having the minimum conductance in solution?

- (1) $[\text{Co}(\text{NH}_3)_3\text{Cl}_3]$
 (2) $[\text{Co}(\text{NH}_3)_4\text{Cl}_2]$
 (3) $[\text{Co}(\text{NH}_3)_6]\text{Cl}_3$
 (4) $[\text{Co}(\text{NH}_3)_5\text{Cl}]\text{Cl}$

64. Match the List-I with List-II.

List-I		List-II	
A.	XeO_3	I.	sp^3d ; linear
B.	XeF_2	II.	sp^3 ; pyramidal
C.	XeOF_4	III.	sp^3d^3 : distorted octahedral
D.	XeF_6	IV.	sp^3d^2 ; square pyramidal

Choose the **correct** answer from the options given below.

- (1) A-II, B-I, C-IV, D-III
 (2) A-II, B-I, C-III, D-IV
 (3) A-IV, B-II, C-III, D-I
 (4) A-IV, B-II, C-I, D-III

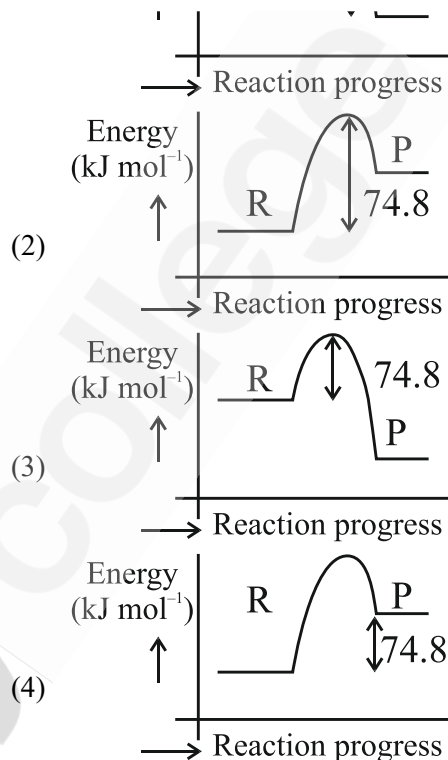

66. Match the List-I with List-II.

List-I (Example)	List-II (Type of Solution)
A. Humidity	I. Solid in solid
B. Alloys	II. Liquid in gas
C. Amalgams	III. Solid in gas
D. Smoke	IV. Liquid in solid

Choose the **correct** answer from the options given below.

- (1) A-II, B-IV, C-I, D-III
 (2) A-II, B-I, C-IV, D-III
 (3) A-III, B-I, C-IV, D-II
 (4) A-III, B-II, C-I, D-IV

67. The correct order of decreasing basic strength of the given amines is:

- (1) N-methylaniline > benzenamine > ethanamine > N-ethylethanamine
 (2) N-ethylethanamine > ethanamine > benzenamine > N-methylaniline
 (3) N-ethylethanamine > ethanamine > N-methylaniline > benzenamine
 (4) benzenamine > ethanamine > N-methylaniline > N-ethylethanamine

below:

- (1) A, B, and C only
- (2) A, B, and D only
- (3) B, C, and D only
- (4) B, D, and E only

69. Match the **List-I** with **List-II**.

List-I	List-II
(Name of Vitamin)	(Deficiency disease)
A. Vitamin B ₁₂	I. Cheilosis
B. Vitamin D	II. Convulsions
C. Vitamin B ₂	III. Rickets
D. Vitamin B ₆	IV. Pernicious anaemia

Choose the **correct** answer from the options given below.

- (1) A-I, B-III, C-II, D-IV
- (2) A-IV, B-III, C-I, D-II
- (3) A-II, B-III, C-I, D-IV
- (4) A-IV, B-III, C-II, D-I

70. The correct order of decreasing acidity of the following aliphatic acids is:

- (1) (CH₃)₃CCOOH > (CH₃)₂CHCOOH > CH₃COOH > HCOOH
- (2) CH₃COOH > (CH₃)₂CHCOOH > (CH₃)₃CCOOH > HCOOH
- (3) HCOOH > CH₃COOH > (CH₃)₂CHCOOH > (CH₃)₃CCOOH
- (4) HCOOH > (CH₃)₃CCOOH > (CH₃)₂CHCOOH > CH₃COOH

71. Given below are two statements;

Statement I: Ferromagnetism is considered as an extreme form of paramagnetism.

Statement II: The number of unpaired electrons in a Cr²⁺ ion (Z=24) is the same as that of a Nd³⁺ ion (Z=60).

In the light of the above statements, choose the **correct** answer from the options given below:

- (1) Both Statement I and Statement II are true
- (2) Both Statement I and Statement II are false
- (3) Statement I is true but Statement II is false
- (4) Statement I is false but Statement II is true

- C. Glycerol from spent-lye III. Fractional distillation
- D. Aniline-water IV. Simple distillation

Choose the **correct** answer from the options given below.

- (1) A-IV, B-III, C-I, D-II
- (2) A-IV, B-III, C-II, D-I
- (3) A-III, B-IV, C-I, D-II
- (4) A-III, B-IV, C-II, D-I

73. For the reaction $A(g) \rightleftharpoons 2B(g)$, the backward reaction rate constant is higher than the forward reaction rate constant by a factor of 2500, at 1000 K. [Given: R= 0.0831 L atm mol⁻¹ K⁻¹]

K_p for the reaction at 1000 K is

- (1) 83.1
- (2) 2.077×10⁵
- (3) 0.033
- (4) 0.021

74. Given below are two statements:

Statement I: Benzenediazonium salt is prepared by the reaction of aniline with nitrous acid at 273-278 K. It decomposes easily in the dry state.

Statement II: Insertion of iodine into the benzene ring is difficult and hence iodobenzene is prepared through the reaction of benzenediazonium salt with KI.

In the light of the above statements, choose the **most appropriate** answer from the options given below:

- (1) Both Statement I and Statement II are correct
- (2) Both Statement I and Statement II are incorrect
- (3) Statement I is correct but Statement II is incorrect
- (4) Statement I is incorrect but Statement II is correct

75. How many products (including stereoisomers) are expected from monochlorination of the following compound?

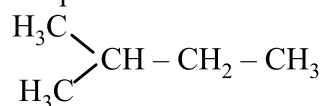

- (1) 2
- (2) 3
- (3) 5
- (4) 6

- I II III
- (1) II > I > III
 - (2) I > II > III
 - (3) III > II > I
 - (4) II > III > I

77. Which one of the following compounds **does not** decolourize bromine water?

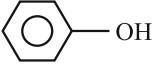
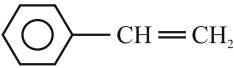
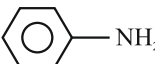
- (1) 
- (2) 
- (3) 
- (4) 

78. The major product of the following reaction is:

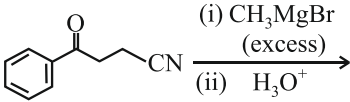
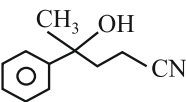
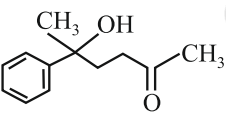
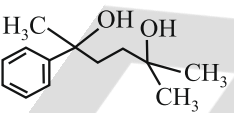
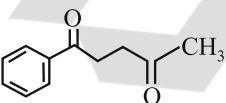
- 
- (1) 
 - (2) 
 - (3) 
 - (4) 

79. Which of the following aqueous solution will exhibit highest boiling point?

- (1) 0.01 M Urea
- (2) 0.01 M KNO₃
- (3) 0.01 M Na₂SO₄
- (4) 0.015 M C₆H₁₂O₆

D. Ziegler IV. TiCl₄ with Al(CH₃)₃ catalyst

Choose the **correct** answer from the options given below:

- (1) A-I, B-II, C-IV, D-III
- (2) A-II, B-III, C-I, D-IV
- (3) A-I, B-II, C-III, D-IV
- (4) A-I, B-IV, C-III, D-II

81. 5 moles of liquid X and 10 moles of liquid Y make a solution having a vapour pressure of 70 torr. The vapour pressures of pure X and Y are 63 torr and 78 torr respectively. Which of the following is true regarding the described solution?

- (1) The solution shows positive deviation.
- (2) The solution shows negative deviation.
- (3) The solution is ideal.
- (4) The solution has volume greater than the sum of individual volumes.

82. Sugar 'X'

- A. is found in honey.
- B. is a keto sugar.
- C. exists in α and β – anomeric forms.
- D. is laevorotatory.

'X' is:

- (1) D-Glucose
- (2) D-Fructose
- (3) Maltose
- (4) Sucrose

83. Identify the suitable reagent for the following conversion.

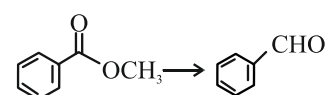

- (1) (i) LiAlH₄, (ii) H⁺/H₂O
- (2) (i) AlH(iBu)₂ (ii) H₂O
- (3) (i) NaBH₄, (ii) H⁺/H₂O
- (4) (i) H₂/Pd-BaSO₄

because of its large size.

In the light of the above statements, choose the **correct** answer from the options given below:

- (1) Both **A** and **R** are true and **R** is the correct explanation of **A**.
- (2) Both **A** and **R** are true but **R** is not the correct explanation of **A**.
- (3) **A** is true but **R** is false.
- (4) **A** is false but **R** is true.

85. The standard heat of formation, in kcal/mol of Ba^{2+} is:

[Given : standard heat of formation of SO_4^{2-} ion (aq) = -216 kcal/mol, standard heat of crystallization of $\text{BaSO}_4(\text{s}) = -4.5$ kcal/mol, standard heat of formation of $\text{BaSO}_4(\text{s}) = -349$ kcal/mol]

- (1) -128.5
- (2) -133.0
- (3) $+133.0$
- (4) $+220.5$

86. Total number of possible isomers (both structural as well as stereoisomers) of cyclic ethers of molecular formula $\text{C}_4\text{H}_8\text{O}$ is:

- (1) 6
- (2) 8
- (3) 10
- (4) 11

87. Identify the correct orders against the property mentioned

- A. $\text{H}_2\text{O} > \text{NH}_3 > \text{CHCl}_3$ - dipole moment
- B. $\text{XeF}_4 > \text{XeO}_3 > \text{XeF}_2$ - number of lone pairs on central atom
- C. $\text{O-H} > \text{C-H} > \text{N-O}$ - bond length
- D. $\text{N}_2 > \text{O}_2 > \text{H}_2$ - bond enthalpy

88. Higher yield of NO in



$[\Delta H \text{ of the reaction} = +180.7 \text{ kJ mol}^{-1}]$

- A. higher temperature
- B. lower temperature
- C. higher concentration of N_2
- D. higher concentration of O_2

Choose the **correct** answer from the options given below:

- (1) A, D only
- (2) B, C only
- (3) B, C, D only
- (4) A, C, D only

89. If the rate constant of a reaction is 0.03 s^{-1} , how much time does it take for 7.2 mol L^{-1} concentration of the reactant to get reduced to 0.9 mol L^{-1} ?

(Given : $\log 2 = 0.301$)

- (1) 69.3 s
- (2) 23.1 s
- (3) 210 s
- (4) 21.0 s

90. Which one of the following reactions does **NOT** belong to "Lassaigne's test"?

- (1) $\text{Na} + \text{C} + \text{N} \xrightarrow{\Delta} \text{NaCN}$
- (2) $2\text{Na} + \text{S} \xrightarrow{\Delta} \text{Na}_2\text{S}$
- (3) $\text{Na} + \text{X} \xrightarrow{\Delta} \text{NaX}$
- (4) $2\text{CuO} + \text{C} \xrightarrow{\Delta} 2\text{Cu} + \text{CO}_2$

92. Polymerase chain reaction (PCR) amplifies DNA following the equation.

- (1) N^2 (2) 2^n
 (3) $2n + 1$ (4) $2N^2$

93. What are the potential drawbacks in adoption of the IVF method?

- A. High fatality risk to mother
 B. Expensive instruments and reagents
 C. Husband/wife necessary for being donors
 D. Less adoption of orphans
 E. Not available in India
 F. Possibility that the early embryo does not survive

Choose the correct answer from the options given below:

- (1) B, D, F only.
 (2) A, C, D, F only
 (3) A, B, C, D only
 (4) A, B, C, E, F only

94. What is the name of the blood vessel that carries deoxygenated blood from the body to the heart in a frog?

- (1) Aorta
 (2) Pulmonary artery
 (3) Pulmonary vein
 (4) Vena cava

95. Which one of the following statements refers to Reductionist Biology?

- (1) Physico-chemical approach to study and understand living organisms.
 (2) Physiological approach to study and understand, living organisms.
 (3) Chemical approach to study and understand living organisms.
 (4) Behavioural approach to study and understand living organisms.

Statement II: DNA evolved from RNA and is a more stable genetic material. Its double helical strands being complementary, resist changes by evolving repairing mechanism.

In the light of the above statements, choose the **most appropriate** answer from the options given below:

- (1) Both statement I and statement II are correct
 (2) Both statement I and statement II are incorrect
 (3) Statement I is correct but statement II is incorrect
 (4) Statement I is incorrect but statement II is correct

97. Epiphytes that are growing on a mango branch is an example of which of the following?

- (1) Commensalism (2) Mutualism
 (3) Predation (4) Amensalism

98. From the statements given below choose the **correct** option:

- A. The eukaryotic ribosomes are 80S and prokaryotic ribosomes are 70S.
 B. Each ribosome has two sub-units.
 C. The two sub-units of 80S ribosome are 60S and 40S while that of 70S are 50S and 30S.
 D. The two sub-units of 80S ribosome are 60S and 20S and that of 70S are 50S and 20S.
 E. The two sub-units of 80S are 60S and 30S and that of 70S are 50S and 30S

- (1) A, B, C are true
 (2) A, B, D are true
 (3) A, B, E are true
 (4) B, D, E are true

99. Which one of the following is an example of ex-situ conservation?

- (1) National Park
 (2) Wildlife Sanctuary
 (3) Zoos and botanical gardens
 (4) Protected areas.

most appropriate answer from the options given below:

- (1) Both statement I and statement II are correct
- (2) Both statement I and statement II are incorrect
- (3) Statement I is correct but statement II is incorrect
- (4) Statement I is incorrect but statement II is correct

101. Match List-I with List-II.

List-I	List-II
A. Emphysema	I. Rapid spasms in muscle due to low Ca^{++} in body fluid
B. Angina Pectoris	II. Damaged alveolar walls and decreased respiratory surface
C. Glomerulo-nephritis	III. Acute chest pain when not enough oxygen is reaching to heart muscle
D. Tetany	IV. Inflammation of glomeruli of kidney

Choose the **correct** answer from the options given below:

- (1) A-III, B-I, C-IV, D-II
- (2) A-III, B-I, C-II, D-IV
- (3) A-II, B-IV, C-III, D-I
- (4) A-II, B-III, C-IV, D-I

pollinated flowers.

In the light of the above statements, choose the **correct** answer from the options given below:

- (1) Both **A** and **R** are true and **R** is the correct explanation of **A**.
- (2) Both **A** and **R** are true but **R** is **NOT** the correct explanation of **A**.
- (3) **A** is true but **R** is false.
- (4) **A** is false but **R** is true.

103. Which of the following is an example of non—distilled alcoholic beverage produced by yeast?

- (1) Whisky
- (2) Brandy
- (3) Beer
- (4) Rum

104. Given below are two statements:

Statement I: In a floral formula \oplus stands for zygomorphic nature of the flower, and \underline{G} stands for inferior ovary.

Statement II: In a floral formula \oplus stands for actinomorphic nature of the flower and \underline{G} stands for superior ovary.

In the light of the above statements, choose the **most appropriate** answer from the options given below:

- (1) Both statement I and statement II are correct
- (2) Both statement I and statement II are incorrect
- (3) Statement I is correct but statement II is incorrect
- (4) Statement I is incorrect but statement II is correct

105. Streptokinase produced by bacterium *Streptococcus* is used for

- (1) Curd production
- (2) Ethanol production
- (3) Liver disease treatment
- (4) Removing clots from blood vessels

107. Which of the following statement is correct about location of the male frog copulatory pad?

- (1) First and Second digit of fore limb
- (2) First digit of hind limb
- (3) Second digit of fore limb
- (4) First digit of the fore limb

108. Which one of the following phytohormones promotes nutrient mobilization which helps in the delay of leaf senescence in plants?

- (1) Ethylene
- (2) Abscisic acid
- (3) Gibberellin
- (4) Cytokinin

109. While trying to find out the characteristic of a newly found animal, a researcher did the histology of adult animal and observed a cavity with presence of mesodermal tissue towards the body wall but no mesodermal tissue was observed towards the alimentary canal. What could be the possible coelome of that animal?

- (1) Acoelomate
- (2) Pseudocoelomate
- (3) Schizocoelomate
- (4) Spongocoelomate

110. Match List-I with List-II.

List-I	List-II
A. Head	I. Enzymes
B. Middle piece	II. Sperm motility
C. Acrosome	III. Energy
D. Tail	IV. Genetic material

111. Given below are the stages in the life cycle of pteridophytes. Arrange the following stages in the correct sequence.

- A. Prothallus stage
- B. Meiosis in spore mother cells
- C. Fertilisation
- D. Formation of archegonia and antheridia in gametophyte.
- E. Transfer of antherozoids to the archegonia in presence of water.

Choose the **correct** answer from the options given below:

- (1) B, A, D, E, C
- (2) B, A, E, C, D
- (3) D, E, C, A, B
- (4) E, D, C, B, A

112. Cardiac activities of the heart are regulated by:

- A. Nodal tissue
- B. A special neural centre in the medulla oblongata
- C. Adrenal medullary hormones
- D. Adrenal cortical hormones

Choose the **correct** answer from the options given below:

- (1) A, B and C Only.
- (2) A, B, C and D
- (3) A, C and D Only
- (4) A, B and D Only

113. Which of following organisms *cannot* fix nitrogen?

- A. *Azotobacter*
- B. *Oscillatoria*
- C. *Anabaena*
- D. *Volvox*
- E. *Nostoc*

Choose the **correct** answer from the options given below:

- (1) A only
- (2) D only
- (3) B only
- (4) E only

most appropriate answer from the options given below:

- (1) Both statement I and statement II are correct
- (2) Both statement I and statement II are incorrect
- (3) Statement I is correct but statement II is incorrect
- (4) Statement I is incorrect but statement II is correct

115.

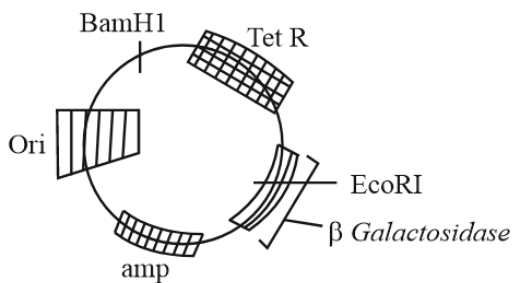

In the above represented plasmid an alien piece of DNA is inserted at EcoRI site. Which of the following strategies will be chosen to select the recombinant colonies?

- (1) Using ampicillin & tetracyclin containing medium plate.
- (2) Blue color colonies will be selected.
- (3) White color colonies will be selected.
- (4) Blue color colonies grown on ampicillin plates can be selected.

116. Which of the following genetically engineered organisms was used by Eli Lilly to prepare human insulin?

- (1) Bacterium
- (2) Yeast
- (3) Virus
- (4) Phage

117. Name the class of enzyme that usually catalyze the following reaction:

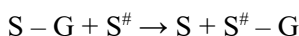

Where, G \rightarrow a group other than hydrogen

S \rightarrow a substrate

S[#] \rightarrow another substrate

- (1) Hydrolase
- (2) Lyase
- (3) Transferase
- (4) Ligase

119. The correct sequence of events in the life cycle of bryophytes is

- A. Fusion of antherozoid with egg.
- B. Attachment of gametophyte to substratum.
- C. Reduction division to produce haploid spores.
- D. Formation of sporophyte.
- E. Release of antherozoids into water.

Choose the **correct** answer from the option given below:

- (1) D, E, A, C, B
- (2) B, E, A, C, D
- (3) B, E, A, D, C
- (4) D, E, A, B, C

120. Which are correct:

- A. Computed tomography and magnetic resonance imaging detect cancers of internal organs.
- B. Chemotherapeutics drugs are used to kill non-cancerous cells.
- C. α -interferon activate the cancer patients' immune system and helps in destroying the tumour.
- D. Chemotherapeutic drugs are biological response modifiers.
- E. In the case of leukaemia blood cells counts are decreased.

Choose the **correct** answer from the option given below:

- (1) B and D only
- (2) D and E only
- (3) C and D only
- (4) A and C only

121. Match List-I with List-II.

List-I	List-II
A. Centromere	I. Mitochondrion
B. Cilium	II. Cell division
C. Cristae	III. Cell movement
D. Cell membrane	IV. Phospholipid Bilayer

Choose the **correct** answer from the options given below:

- (1) A-I, B-II, C-III, D-IV
- (2) A-II, B-I, C-IV, D-III
- (3) A-IV, B-II, C-III, D-I
- (4) A-II, B-III, C-I, D-IV

Yellow-orange

Choose the option with all **correct** matches.

- (1) A-III, B-IV, C-II, D-I
- (2) A-III, B-I, C-II, D-IV
- (3) A-I, B-II, C-IV, D-III
- (4) A-I, B-IV, C-III, D-II

123. Find the correct statements:

- A. In human pregnancy, the major organ systems are formed at the end of 12 weeks.
- B. In human pregnancy the major organ systems are formed at the end of 8 weeks.
- C. In human pregnancy heart is formed after one month of gestation.
- D. In human pregnancy, limbs and digits develop by the end of second month.
- E. In human pregnancy the appearance of hair usually observed in the fifth month.

Choose the **correct** answer from the options given below:

- (1) A and E Only
- (2) B and C Only
- (3) B, C, D and E Only
- (4) A, C, D and E Only

124. In the seeds of cereals, the outer covering of endosperm separates the embryo by a protein-rich layer called:

- (1) Coleoptile
- (2) Coleorhiza
- (3) Integument
- (4) Aleurone layer

125. Which of the following diagrams is correct with regard to the proximal (P) and distal (D) tubule of the Nephron.

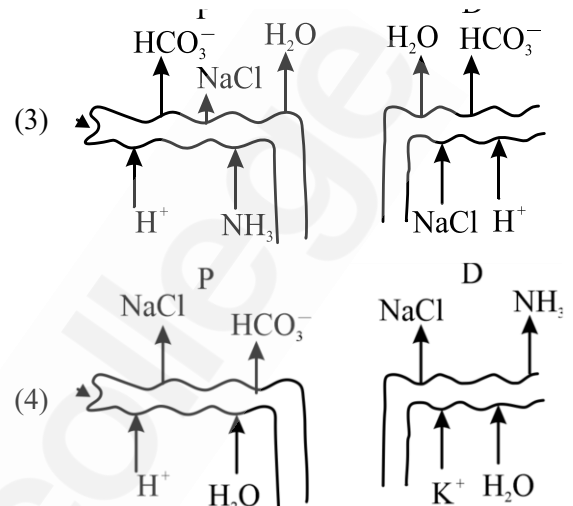
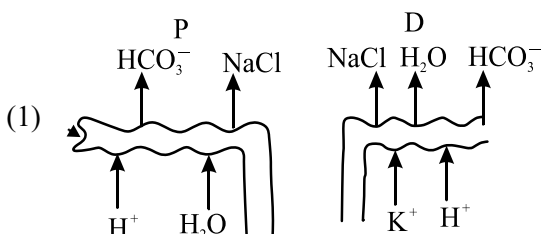

126. Identify the part of a bio-reactor which is used as a foam braker from the given figure.

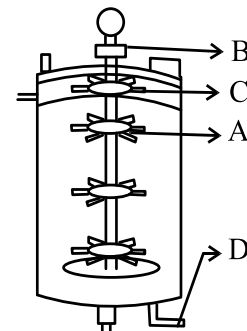

- (1) A
- (2) B
- (3) D
- (4) C

127. Given below are two statements: One is labelled as **Assertion (A)** and the other is labelled as **Reason (R)**.

Assertion (A): A typical unfertilized, angiosperm embryo sac at maturity is 8 nucleate and 7-celled.

Reason (R): The egg apparatus has 2 polar nuclei.

In the light of the above statements, choose the **correct** answer from the options given below:

- (1) Both **A** and **R** are true and **R** is the correct explanation of **A**.
- (2) Both **A** and **R** are true but **R** is **NOT** the correct explanation of **A**.
- (3) **A** is true but **R** is false.
- (4) **A** is false but **R** is true.

events in an eukaryotic cell?

- A. Transport of pre-mRNA to cytoplasm prior to splicing.
- B. Removal of introns and joining of exons.
- C. Addition of methyl group at 5' end of hnRNA.
- D. Addition of adenine residues at 3' end of hnRNA.
- E. Base pairing of two complementary RNAs.

Choose the **correct** answer from the options given below:

- (1) A, B, C only (2) B, C, D only
- (3) B, C, E only (4) C, D, E only

130. What is the pattern of inheritance for polygenic trait?

- (1) Mendelian inheritance pattern
- (2) Non-mendelian inheritance pattern
- (3) Autosomal dominant pattern
- (4) X-linked recessive inheritance pattern

131. Which one of the following enzymes contains 'Haem' as the prosthetic group?

- (1) RuBisCo
- (2) Carbonic anhydrase
- (3) Succinate dehydrogenase
- (4) Catalase

132. Each of the following characteristics represent a Kingdom proposed by Whittaker. Arrange the following in increasing order of complexity of body organization.

- A. Multicellular heterotrophs with cell wall made of chitin.
- B. Heterotrophs with tissue/organ/organ system level of body organization.
- C. Prokaryotes with cell wall made of polysaccharides and amino acids.
- D. Eukaryotic autotrophs with tissue/organ level of body organization.
- E. Eukaryotes with cellular body organization.

133. Who is known as the father of Ecology in India?

- (1) S. R. Kashyap
- (2) Ramdeo Misra
- (3) Ram Udar
- (4) Birbal Sahni

134. Match List-I with List-II.

List-I		List-II	
A.	Alfred Hershey and Martha Chase	I.	Streptococcus Pneumoniae
B.	Euchromatin	II.	Densely packed and dark-stained
C.	Frederick Griffith	III.	Loosely packed and light-stained
D.	Heterochromatin	IV.	DNA as genetic material confirmation

Choose the **correct** answer from the options given below:

- (1) A-II, B-IV, C-I, D-III
- (2) A-IV, B-II, C-I, D-III
- (3) A-IV, B-III, C-I, D-II
- (4) A-III, B-II, C-IV, D-I

135. Neoplastic characteristics of cells refers to:

- A. A mass of proliferating cell
- B. Rapid growth of cells
- C. Invasion and damage to the surrounding tissue
- D. Those confined to original location

Choose the **correct** answer from the options given below:

- (1) A, B only
- (2) A, B, C only
- (3) A, B, D only
- (4) B, C, D only

appropriate answer from the options given below:

- (1) Both statement I and statement II are correct
- (2) Both statement I and statement II are incorrect
- (3) Statement I is correct but statement II is incorrect
- (4) Statement I is incorrect but statement II is correct

137. Match **List I** with **List II**.

List I	List II
A. Adenosine	I. Nitrogen base
B. Adenylic acid	II. Nucleotide
C. Adenine	III. Nucleoside
D. Alanine	IV. Amino acid

Choose the option with all **correct** matches.

- (1) A-III, B-IV, C-II, D-I
- (2) A-III, B-II, C-IV, D-I
- (3) A-III, B-II, C-I, D-IV
- (4) A-II, B-III, C-I, D-IV

138. Consider the following:

- A. The reductive division for the human female gametogenesis starts earlier than that of the male gametogenesis.
- B. The gap between the first meiotic division and the second meiotic division is much shorter for males compared to females.
- C. The first polar body is associated with the formation of the primary oocyte.
- D. Luteinizing Hormone (LH) surge leads to disintegration of the endometrium and onset of menstrual bleeding.

Choose the **correct** answer from the options given below:

- (1) A and B are true
- (2) A and C are true
- (3) B and D are true
- (4) B and C are true

139. All living members of the class Cyclostomata are:

- (1) Free living
- (2) Endoparasite
- (3) Symbiotic
- (4) Ectoparasite

the endoplasmic reticulum fuse with the cis face of the Golgi apparatus, and they are modified and released from the trans face of the Golgi apparatus.

In the light of the above statements, choose the **correct** answer from the options given below:

- (1) Both **A** and **R** are true and **R** is the correct explanation of **A**
- (2) Both **A** and **R** are true but **R** is not the correct explanation of **A**
- (3) **A** is true but **R** is false
- (4) **A** is false but **R** is true

141. Match **List I** with **List II**.

List I	List II
A. Scutellum	I. Persistent nucellus
B. Non-albuminous seed	II. Cotyledon of Monocot seed
C. Epiblast	III. Groundnut
D. Perisperm	IV. Rudimentary cotyledon

Choose the option with all **correct** matches.

- (1) A-II, B-III, C-IV, D-I
- (2) A-IV, B-III, C-II, D-I
- (3) A-IV, B-III, C-I, D-II
- (4) A-II, B-IV, C-III, D-I

142. Given below are two statements : one is labelled as **Assertion (A)** and the other is labelled as **Reason (R)**.

Assertion (A): All vertebrates are chordates but all chordates are not vertebrate.

Reason (R): The members of subphylum vertebrata possess notochord, during the embryonic period, the notochord is replaced by a cartilaginous or bony vertebral column in adults.

In the light of the above statements, choose the **correct** answer from the options given below:

- (1) Both **A** and **R** are true and **R** is the correct explanation of **A**
- (2) Both **A** and **R** are true but **R** is not the correct explanation of **A**
- (3) **A** is true but **R** is false
- (4) **A** is false but **R** is true

(4) Constant region of heavy and light chains are located at C-terminus of antibody molecules.

144. Silencing of specific mRNA is possible via RNAi because of -

- (1) Complementary dsRNA
- (2) Inhibitory ssRNA
- (3) Complementary tRNA
- (4) Non-complementary ssRNA

145. Genes R and Y follow independent assortment. If RRYY produce round yellow seeds and rryy produce wrinkled green seeds, what will be the phenotypic ratio of the F₂ generation?

- (1) Phenotypic ratio - 1 : 2 : 1
- (2) Phenotypic ratio - 3 : 1
- (3) Phenotypic ratio - 9 : 3 : 3 : 1
- (4) Phenotypic ratio - 9 : 7

146. Histones are enriched with -

- (1) Lysine & Arginine
- (2) Leucine & Lysine
- (3) Phenylalanine & Leucine
- (4) Phenylalanine & Arginine

147. The first menstruation is called:

- (1) Menopause
- (2) Menarche
- (3) Diapause
- (4) Ovulation

148. Match List - I with List - II.

List - I

- A. Heart
- B. Kidney
- C. Gastro-intestinal tracts
- D. Adrenal Cortex

List - II

- I. Erythropoietin
- II. Aldosterone
- III. Atrial natriuretic factor
- IV. Secretin

Choose the **correct** answer from the options given below:

- (1) A-II, B-I, C-III, D-IV
- (2) A-IV, B-III, C-II, D-I
- (3) A-I, B-III, C-IV, D-II
- (4) A-III, B-I, C-IV, D-II

150. Which of the following is the unit of productivity of an Ecosystem?

- (1) gm⁻²
- (2) KCal m⁻²
- (3) KCal m⁻³
- (4) (KCal m⁻²)yr⁻¹

151. Sweet potato and potato represent a certain type of evolution. Select the correct combination of terms to explain the evolution.

- (1) Analogy, convergent
- (2) Homology, divergent
- (3) Homology, convergent
- (4) Analogy, divergent

152. With the help of given pedigree, find out the probability for the birth of a child having no disease and being a carrier (has the disease mutation in one allele of the gene) in F₃ generation.

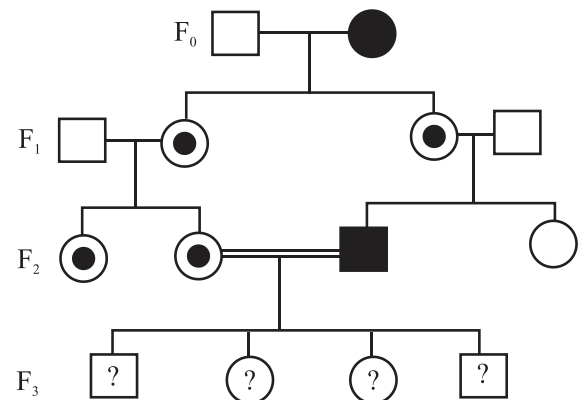

- Unaffected male
- Affected male
- Carrier female
- Unaffected female
- Affected female

- (1) 1/4
- (2) 1/2
- (3) 1/8
- (4) Zero

the tapetum increases the efficiency of nourishing the developing microspore mother cells.

In the light of the above statements, choose the **most appropriate** answer from the options given below:

- (1) Both **A** and **R** are true and **R** is the correct explanation of **A**
- (2) Both **A** and **R** are true but **R** is not the correct explanation of **A**
- (3) **A** is true but **R** is false
- (4) **A** is false but **R** is true

154. How many meiotic and mitotic divisions need to occur for the development of a mature female gametophyte from the megaspore mother cell in an angiosperm plant?

- (1) 2 Meiosis and 3 Mitosis
- (2) 1 Meiosis and 2 Mitosis
- (3) 1 Meiosis and 3 Mitosis
- (4) No Meiosis and 2 Mitosis

155. Which of the following is an example of a zygomorphic flower?

- (1) Petunia
- (2) Datura
- (3) Pea
- (4) Chilli

156. After maturation, in primary lymphoid organs, the lymphocytes migrate for interaction with antigens to secondary lymphoid organ(s)/tissue(s) like:

- A. thymus
- B. bone marrow
- C. spleen
- D. lymph nodes
- E. Peyer's patches

Choose the *correct* answer from the options given below:

- (1) B, C, D only
- (2) A, B, C only
- (3) E, A, B only
- (4) C, D, E only

- (1) Both statement I and statement II are correct
- (2) Both statement I and statement II are incorrect
- (3) Statement I is correct but statement II is incorrect
- (4) Statement I is incorrect but statement II is correct

158. What is the main function of the spindle fibers during mitosis?

- (1) To separate the chromosomes
- (2) To synthesize new DNA
- (3) To repair damaged DNA
- (4) To regulate cell growth

159. Which one of the following is the characteristic feature of gymnosperms?

- (1) Seeds are enclosed in fruits.
- (2) Seeds are naked.
- (3) Seeds are absent.
- (4) Gymnosperms have flowers for reproduction.

160. Consider the following statements regarding function of adrenal medullary hormones:

- A. It causes pupillary constriction
- B. It is a hyperglycemic hormone
- C. It causes piloerection
- D. It increases/strength of heart contraction

Choose the **correct** answer from the options given below:

- (1) C and D Only
- (2) B, C and D Only
- (3) A, C and D Only
- (4) D Only

161. Why can't insulin be given orally to diabetic patients?

- (1) Human body will elicit strong immune response
- (2) It will be digested in Gastro-Intestinal (GI) tract
- (3) Because of structural variation
- (4) Its bioavailability will be increased

D. Gymnosperm IV. *Salvinia*

Choose the option with all **correct** matches.

- (1) A-III, B-IV, C-II, D-I
- (2) A-IV, B-III, C-I, D-II
- (3) A-III, B-IV, C-I, D-II
- (4) A-IV, B-III, C-II, D-I

163. Who proposed that the genetic code for amino acids should be made up of three nucleotides?

- (1) George Gamow
- (2) Francis Crick
- (3) Jacque Monod
- (4) Franklin Stahl

164. Match **List-I** with **List-II**.

List-I	List-II
A. The Evil I. Quartet	Cryopreservation
B. Ex situ II. conservation	Alien species invasion
C. <i>Lantana camara</i> III.	Causes of biodiversity losses
D. Dodo IV.	Extinction

Choose the option with all **correct** matches.

- (1) A-III, B-II, C-I, D-IV
- (2) A-III, B-I, C-II, D-IV
- (3) A-III, B-IV, C-II, D-I
- (4) A-III, B-II, C-IV, D-I

165. Which of the following hormones released from the pituitary is actually synthesized in the hypothalamus?

- (1) Luteinizing hormone (LH)
- (2) Anti-diuretic hormone (ADH)
- (3) Follicle-stimulating hormone (FSH)
- (4) Adenocorticotrophic hormone (ACTH)

Choose the **correct** answer from the options given below:

- (1) A and B Only
- (2) A and C Only
- (3) B and C Only
- (4) B, D and E Only

167. Which of the following type of immunity is present at the time of birth and is a non-specific type of defence in the human body?

- (1) Acquired Immunity
- (2) Innate Immunity
- (3) Cell-mediated Immunity
- (4) Humoral Immunity

168. In bryophytes, the gemmae help in which one of the following?

- (1) Sexual reproduction
- (2) Asexual reproduction
- (3) Nutrient absorption
- (4) Gaseous exchange

169. In frog, the Renal portal system is a special venous connection that acts to link :

- (1) Liver and intestine
- (2) Liver and kidney
- (3) Kidney and intestine
- (4) Kidney and lower part of body

170. Given below are two statements:

Statement I: In ecosystem, there is unidirectional flow of energy of sun from producers to consumers.

Statement II: Ecosystems are exempted from 2nd law of thermodynamics.

In the light of the above statements, choose the **most appropriate** answer from the options given below:

- (1) Both Statement I and Statement II are correct
- (2) Both Statement I and Statement II are incorrect
- (3) Statement I is correct but Statement II is incorrect
- (4) Statement I is incorrect but Statement II is correct

(4) It catalyzes the carboxylation of RuBP.

172. Which of the following enzyme(s) are **NOT** essential for gene cloning?

- A. Restriction enzymes
- B. DNA ligase
- C. DNA mutase
- D. DNA recombinase
- E. DNA polymerase

Choose the **correct** answer from the options given below :

- (1) C and D only
- (2) A and B only
- (3) D and E only
- (4) B and C only

173. Read the following statements on plant growth and development.

- A. Parthenocarpy can be induced by auxins.
- B. Plant growth regulators can be involved in promotion as well as inhibition of growth.
- C. Dedifferentiation is a pre-requisite for re-differentiation.
- D. Abscisic acid is a plant growth promoter.
- E. Apical dominance promotes the growth of lateral buds.

Choose the option with all correct statements.

- (1) A, B, C only
- (2) A, C, E only
- (3) A, D, E only
- (4) B, D, E only

174. Which factor is important for termination of transcription?

- (1) α (alpha)
- (2) σ (sigma)
- (3) ρ (rho)
- (4) γ (gamma)

land

(4) The statement is false for both the environment

176. Twins are born to a family that lives next door to you. The twins are a boy and a girl. Which of the following must be true?

- (1) They are monozygotic twins.
- (2) They are fraternal twins.
- (3) They were conceived through in vitro fertilization.
- (4) They have 75% identical genetic content.

177. Which of the following microbes is **NOT** involved in the preparation of household products?

- A. *Aspergillus niger*
- B. *Lactobacillus*
- C. *Trichoderma polysporum*
- D. *Saccharomyces cerevisiae*
- E. *Propionibacterium sharmanii*

Choose the **correct** answer from the options given below:

- (1) A and B only (2) A and C only
- (3) C and D only (4) C and E only

178. Match **List-I** with **List-II**.

List-I	List-II
A. Progesterone	I. Pars intermedia
B. Relaxin	II. Ovary
C. Melanocyte stimulating hormone	III. Adrenal Medulla
D. Catecholamines	IV. Corpus luteum

Choose the **correct** answer from the options given below:

- (1) A-IV, B-II, C-I, D-III
- (2) A-IV, B-II, C-III, D-I
- (3) A-II, B-IV, C-I, D-III
- (4) A-III, B-II, C-IV, D-I

Statement II: The colonies without blue colour have DNA insert in the plasmid and are identified as recombinant colonies.

In the light of the above statements, choose the **most appropriate** answer from the options given below:

- (1) Both Statement I and Statement II are correct
- (2) Both Statement I and Statement II are incorrect
- (3) Statement I is correct but Statement II is incorrect
- (4) Statement I is incorrect but Statement II is correct

$$(2) \frac{dN}{dt} = rN \left(\frac{N - K}{K} \right)$$

$$(3) \frac{dN}{dt} = rN \left(\frac{N - K}{N} \right)$$

$$(4) \frac{dN}{dt} = N \left(\frac{r - K}{K} \right)$$



PW Web/App - <https://smart.link/7wwosivoicgd4>

Library- <https://mart.link/sdfez8ejd80if>

|| DATE: 04-05-2025 ||

ANSWER KEY

- | | | | |
|---------|-----------|----------|----------|
| 1. (2) | 46. (4) | 91. (2) | 136. (1) |
| 2. (2) | 47. (2) | 92. (2) | 137. (3) |
| 3. (2) | 48. (2) | 93. (1) | 138. (1) |
| 4. (4) | 49. (1) | 94. (4) | 139. (4) |
| 5. (2) | 50. (1) | 95. (1) | 140. (1) |
| 6. (2) | 51. (3) | 96. (1) | 141. (1) |
| 7. (4) | 52. (3) | 97. (1) | 142. (1) |
| 8. (4) | 53. (2) | 98. (1) | 143. (3) |
| 9. (1) | 54. (4) | 99. (3) | 144. (1) |
| 10. (1) | 55. (1) | 100. (3) | 145. (3) |
| 11. (4) | 56. (4) | 101. (4) | 146. (1) |
| 12. (1) | 57. (2) | 102. (2) | 147. (2) |
| 13. (3) | 58. (4) | 103. (3) | 148. (4) |
| 14. (3) | 59. (4) | 104. (4) | 149. (3) |
| 15. (2) | 60. (4) | 105. (4) | 150. (4) |
| 16. (2) | 61. (3) | 106. (3) | 151. (1) |
| 17. (4) | 62. (2) | 107. (4) | 152. (1) |
| 18. (2) | 63. (1,2) | 108. (4) | 153. (3) |
| 19. (3) | 64. (1) | 109. (2) | 154. (3) |
| 20. (1) | 65. (1) | 110. (1) | 155. (3) |
| 21. (4) | 66. (2) | 111. (1) | 156. (4) |
| 22. (2) | 67. (3) | 112. (1) | 157. (2) |
| 23. (2) | 68. (2) | 113. (2) | 158. (1) |
| 24. (3) | 69. (2) | 114. (4) | 159. (2) |
| 25. (3) | 70. (3) | 115. (3) | 160. (2) |
| 26. (3) | 71. (3) | 116. (1) | 161. (2) |
| 27. (1) | 72. (1) | 117. (3) | 162. (2) |
| 28. (4) | 73. (3) | 118. (1) | 163. (1) |
| 29. (2) | 74. (1) | 119. (3) | 164. (2) |
| 30. (3) | 75. (4) | 120. (4) | 165. (2) |
| 31. (1) | 76. (1) | 121. (4) | 166. (2) |
| 32. (2) | 77. (1) | 122. (2) | 167. (2) |
| 33. (3) | 78. (2) | 123. (4) | 168. (2) |
| 34. (2) | 79. (3) | 124. (4) | 169. (4) |
| 35. (2) | 80. (3) | 125. (2) | 170. (3) |
| 36. (2) | 81. (2) | 126. (4) | 171. (4) |
| 37. (3) | 82. (2) | 127. (3) | 172. (1) |
| 38. (1) | 83. (2) | 128. (1) | 173. (1) |
| 39. (3) | 84. (1) | 129. (2) | 174. (3) |
| 40. (2) | 85. (1) | 130. (2) | 175. (3) |
| 41. (2) | 86. (3) | 131. (4) | 176. (2) |
| 42. (3) | 87. (1) | 132. (2) | 177. (2) |
| 43. (3) | 88. (4) | 133. (2) | 178. (1) |
| 44. (4) | 89. (1) | 134. (3) | 179. (4) |
| 45. (2) | 90. (4) | 135. (2) | 180. (2) |

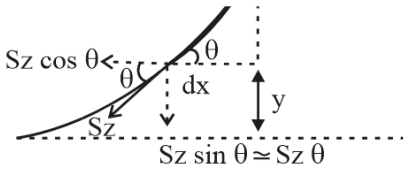

$$F_y = Sz \cdot d\theta = (dx)z\rho gy$$

= weight of liquid lifted..... (1)

$$\tan\theta \approx \theta = \frac{dy}{dx}$$

$$\Rightarrow \frac{d\theta}{dx} = \frac{d^2y}{dx^2}$$

$$d\theta = \frac{d^2y}{dx^2} \cdot dx \quad \dots\dots (2)$$

from equations (1) and (2)

$$Sz \left(\frac{d^2y}{dx^2} \cdot dx \right) = (dx)z\rho gy$$

$$\frac{d^2y}{dx^2} = \frac{\rho g}{S} \cdot y$$

Q2 Text Solution:

$$m = \frac{L}{f_o} \frac{D}{f_e} = \frac{40}{2} \frac{25}{4} = 20 \times 6.25 = 125$$

Q3 Text Solution:

For zero lorentz force E must be perpendicular to B

$$qE = qvB$$

$$v = c/100 = 3 \times 10^6 \text{ m s}^{-1},$$

$$B = 9 \times 10^{-4} \text{ T}$$

$$E = vB = (3 \times 10^6)(9 \times 10^{-4}) = 27 \times 10^2 \text{ V m}^{-1}$$

Q4 Text Solution:

Thought for 8 seconds

$$a_s = g \sin 45^\circ \text{ (smooth)}$$

$$a_r = g \sin 45^\circ - \mu_k g \cos 45^\circ \text{ (rough)}$$

$$\frac{t_r}{t_s} = \sqrt{\frac{a_s}{a_r}} = 2 \Rightarrow a_r = \frac{a_s}{4}$$

$$g \sin 45^\circ - \mu_k g \cos 45^\circ = \frac{g \sin 45^\circ}{4}$$

$$\Rightarrow \mu_k = \frac{3 \sin 45^\circ}{4 \cos 45^\circ} = \frac{3}{4} \tan 45^\circ = 0.75$$

Q5 Text Solution:

$$\frac{A}{B} = \frac{3}{\bar{3}}$$

Q6 Text Solution:

Resistance of 6Ω is removed as it is balanced wheatstone bridge

$$R_{BE} = \frac{4 \times 8}{4+8} = \frac{8}{3} \Omega$$

$$R_{Total} = \left(\frac{8}{3} + 1.5 + 5.5 + \frac{1}{3} \right) \Omega = 10 \Omega$$

$$V = i R_{Total}$$

$$5 = i \times 10$$

$$i = 0.5 \text{ A}$$

Q7 Text Solution:

At point P

$$mg \sin \theta = \frac{mv^2}{l}$$

$$v = \sqrt{gl \sin \theta} \dots\dots (i)$$

Using energy conservation between lowest point and P .

$$\frac{1}{2}mv_0^2 = \frac{1}{2}mv^2 + mg(l + l \sin \theta) \dots\dots (ii)$$

From i

$$v_0 = \sqrt{3gl \sin \theta + 2gl}$$

$$\frac{v}{v_0} = \sqrt{\frac{\sin \theta}{2+3 \sin \theta}}$$

Q8 Text Solution:

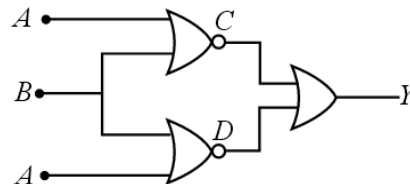

A	B	C	D	Y
0	0	1	1	1
0	1	0	0	0
1	0	0	0	0
1	1	0	0	0

So it is a NOR gate.

Q9 Text Solution:

$$E_z = 60 \cos(5x + 1.5 \times 10^9 t) \text{ V m}^{-1}.$$

$$B_0 = E_0/c = 60/(3 \times 10^8) = 2 \times 10^{-7} \text{ T}$$

Phase is $kx + \omega t \Rightarrow$ propagation along $-\hat{x}$.

So B is along Y -axis

(upward).

$$\begin{aligned} \text{Impulse } J &= m(v_f - (-v_i)) = m(v_f + v_i) \\ &= 0.5(14 + 28) = 21 \text{ N s (units: kg m s}^{-1} = \text{N s)}. \end{aligned}$$

Q11 Text Solution:

Elements from A → B: Inductor ($L = 1 \text{ H}$),
Battery 5 V (+ on A-side),
Resistor ($R = 2 \Omega$)

$$\begin{aligned} V_{AB} &= V_{\text{ind}} + V_{\text{bat}} + V_R \\ &= L \frac{di}{dt} + 5 \text{ V} + IR \\ &= 1 \text{ H}(1 \text{ A s}^{-1}) + 5 \text{ V} + (2 \text{ A})(2 \Omega) \\ &= 1 \text{ V} + 5 \text{ V} + 4 \text{ V} = 10 \text{ V} \end{aligned}$$

The potential drop across an inductor is $L di/dt$; across a resistor it is IR ; the ideal battery adds its emf. Summing these gives the net potential difference $V_A - V_B$.

Q12 Text Solution:

$$m = NIA \text{ for a circular coil.}$$

With the same current (2 A) and equal single turns,

$$\frac{m_1}{m_2} = \frac{A_1}{A_2} = \frac{\pi r_1^2}{\pi r_2^2} = \left(\frac{1}{2}\right)^2 = \frac{1}{4}.$$

magnetic moment is proportional to the square of the coil's radius, so doubling the radius quadruples the moment.

Q13 Text Solution:

For thin lenses in contact, powers add:

$$P_{\text{comb}} = P_1 + P_2 + P_3 + P_4 = 4p.$$

Each lens gives linear magnification m ;

successive elements multiply, so the overall magnification is

$$M = m \times m \times m \times m = m^4 \text{ (dimensionless).}$$

Hence the combination has power $4p$ and magnification m^4 .

absolute $P_f = 12(1.01 \times 10^5) \text{ Pa.} \Rightarrow$

$$\begin{aligned} n_f &= \frac{P_f V}{RT} = \frac{12(1.01 \times 10^5)(0.03)}{\left(\frac{100}{12}\right)(300)} \\ &\approx 14.55 \text{ mol} \end{aligned}$$

Moles removed $n_w = n_i - n_f \approx 3.65 \text{ mol.}$

Mass withdrawn

$$m = n_w M_{O_2} = 3.65 \times 32 \text{ g} \approx 0.116 \text{ kg.}$$

ideal-gas relation gives the number of moles remaining; their difference times molar mass yields the mass of oxygen taken out.

Q15 Text Solution:

Velocity

$$v = \frac{dx}{dt} = \left(\frac{dt}{dx}\right)^{-1} = \frac{1}{2x+1}.$$

Acceleration

$$a = \frac{dv}{dt} = \frac{dv}{dx} \frac{dx}{dt} \text{ (Chain Rule)}$$

$$= \left[-\frac{2}{(2x+1)^2}\right] \frac{1}{2x+1} = -\frac{2}{(2x+1)^3}.$$

Q16 Text Solution:

null

$$I_{\text{rms}} = V/Z = 220/28.3 \approx 7.8 \text{ A}$$

$$\phi = \tan^{-1}((X_L - X_C)/R) = \tan^{-1}(1)$$

$$= 45^\circ$$

(current lags, net inductive)

current 7.8 A , phase angle 45° ; results follow directly from the series-RLC impedance and phase relations.

Q17 Text Solution:

Angular momentum about the axis is conserved (no external torque).

$$I_1 \omega_1 = I_2 \omega_2,$$

$$I = \frac{2}{5} MR^2 \text{ (uniform solid sphere)}$$

When the radius doubles: $I_2 = 4I_1$.

$\phi = BA$

$$B\pi r^2 = n\frac{h}{e}, \quad n = 1 \Rightarrow r^2 = \frac{h}{\pi eB}$$

For uniform circular motion

$$evB = \frac{mv^2}{r} \Rightarrow v = \frac{eBr}{m}$$

Current in the orbit

$$I = \frac{e}{T} = \frac{ev}{2\pi r} = \frac{e^2 B}{2\pi m}$$

Magnetic moment

$$\begin{aligned} \mu = IA &= I\pi r^2 = \frac{e^2 B}{2\pi m} \pi r^2 = \frac{e^2 B}{2\pi m} \frac{h}{eB} \\ &= \boxed{\frac{he}{2\pi m}} \end{aligned}$$

Q19 Text Solution:

Steady heat current (rods all length L):

$$2KA \frac{3T - T_1}{L} = KA \frac{T_1 - T_2}{L} = 2KA \frac{T_2 - T}{L}$$

$$2(3T - T_1) = T_1 - T_2 = 2(T_2 - T)$$

Let that common value be J .

From the two end equalities:

- $J = 2(3T - T_1) \Rightarrow T_1 = 3T - \frac{J}{2}$
- $J = 2(T_2 - T) \Rightarrow T_2 = T + \frac{J}{2}$

Insert into $T_1 - T_2 = J$:

$$(3T - \frac{J}{2}) - (T + \frac{J}{2}) = J \Rightarrow J = T$$

$$\text{Thus } T_1 = \frac{5T}{2}, \quad T_2 = \frac{3T}{2}$$

$$\boxed{\frac{T_1}{T_2} = \frac{5}{3}}$$

Q20 Text Solution:

$$\begin{aligned} C_1 &= \frac{K_1 \epsilon_0 A}{t_1} = \frac{K_1 \epsilon_0 A}{\frac{3d}{8}} = \frac{8}{3} K_1 \left(\frac{\epsilon_0 A}{d} \right) \\ &= \frac{8}{3} K_1 C_0 \end{aligned}$$

$$\frac{1}{C_{new}} = \left[\frac{3}{8K_1} + \frac{1}{2K_2} + \frac{1}{8} \right] \times \frac{1}{C_0}$$

$$\therefore C_{new} = 2C_0$$

$$\frac{1}{2} = \frac{3}{8K_1} + \frac{1}{2K_2} + \frac{1}{8}$$

$$\frac{1}{2} - \frac{1}{8} = \frac{3}{8K_1} + \frac{1}{2K_2}$$

$$\frac{3}{8} = \frac{3}{8K_1} + \frac{4}{8K_2}$$

multiply by 8

$$3 = \frac{3}{K_1} + \frac{4}{K_2}$$

$$K_1 = 1.25, \quad K_2 = \left(\frac{5}{4}\right) \cdot K_2$$

$$3 = \frac{12+20}{5K_2}$$

$$[K_2 = \frac{32}{15}]$$

$$K_1 = \frac{5}{4} K_2 = \frac{160}{60} = \frac{16}{6}$$

$$K_1 = \frac{8}{3}$$

$$K_1 \approx 2.667$$

Q21 Text Solution:

Let bus speed = $V \text{ km h}^{-1}$; buses leave each city every T min.

Spacing between successive buses in either lane $s = V(T/60)$ km.

Same direction (girl overtaken every 30 min = 0.5 h):

$$\frac{s}{V-60} = 0.5 \Rightarrow \frac{VT}{60(V-60)} = 0.5 \quad \text{(i)}$$

Opposite direction (bus meets her every 10 min = 1/6 h):

$$\frac{s}{V+60} = \frac{1}{6} \Rightarrow \frac{VT}{60(V+60)} = \frac{1}{6} \quad \text{(ii)}$$

Equating T from (i) and (ii):

$$30 \times \frac{V-60}{V} = 10 \times \frac{V+60}{V} \Rightarrow 3(V-60)$$

$$= V+60 \Rightarrow V = 120 \text{ km h}^{-1}$$

Putting the value of V in (ii):

$$T = 10 \times \frac{V+60}{V} = 10 \times \frac{180}{120} = 15 \text{ min.}$$

Answer: 15 min period, 120 km h⁻¹ bus speed .

Q22 Text Solution:

Weight

$$W = mg = 20 \text{ kg} \times 10 \text{ m s}^{-2} = 200\text{N.}$$

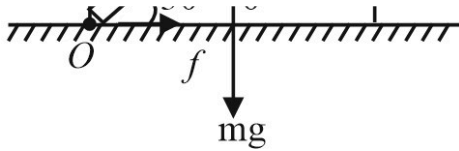

Rod angle with horizontal

$$\theta = 90^\circ - 60^\circ = 30^\circ.$$

Equilibrium

Horizontal equilibrium: $f = N_w$,

Vertical equilibrium.: $N_f = W$.

Torque about O (anticlockwise = clockwise):

$$N_w l \sin \theta = W (l/2) \cos \theta \implies N_w = \frac{W}{2} \cot \theta.$$

$$N_w = \frac{200}{2} \cot 30^\circ = 100\sqrt{3} \text{ N}.$$

Hence friction $f = N_w = 100\sqrt{3} \text{ N}$.

Q23 Text Solution:

For a spring – mass oscillator $\omega = \sqrt{k/m}$.

- Sand leaks out \implies mass $m(t)$ gradually **decreases** $\implies \omega(t) \propto 1/\sqrt{m}$ **increases** with time.
- as every grain that leaves, so the total mechanical energy falls and the **amplitude** $A(t)$ **decreases** steadily.

The only sketch showing $\omega(t)$ rising while $A(t)$ falls is.

Q24 Text Solution:

Excess pressure in a spherical balloon

$$\Delta p = \frac{2S}{r} \quad (\text{surface-tension law}).$$

Outlet speed (Bernoulli)

$$\frac{1}{2} \rho v^2 \simeq \Delta p \implies v(r) \propto \sqrt{\frac{S}{\rho r}} \implies v \propto r^a, \quad a = -\frac{1}{2}.$$

$$dt = \frac{4\pi}{A} S^{-1/2} \rho^{1/2} r^{5/2} dr.$$

$$T = \int_0^R dt = \frac{4\pi}{A} S^{-1/2} \rho^{1/2} \int_0^R r^{5/2} dr$$

$$\propto S^{-1/2} A^{-1} \rho^{1/2} R^{7/2}.$$

So $T \propto S^\alpha A^\beta \rho^\gamma R^\delta$ with

$$a = -\frac{1}{2}, \quad \alpha = -\frac{1}{2}, \quad \beta = -1, \quad \gamma = \frac{1}{2},$$

$$\delta = \frac{7}{2}.$$

Q25 Text Solution:

Least count

$$LC = 1 \text{ MSD} - 1 \text{ VSD} = 0.10 - \frac{9}{10} \times 0.10.$$

$$= 0.01 \text{ cm}$$

Observed reading = MSR + (VSD \times LC)

$$= 5 \text{ cm} + (8 \times 0.01 \text{ cm})$$

$$= 5.08 \text{ cm}$$

Corrected reading = Observed reading - Zero error

$$= 5.08 \text{ cm} - (+0.1 \text{ cm})$$

$$= 4.98 \text{ cm}$$

Q26 Text Solution:

$$E = \frac{\sigma}{\epsilon_0}$$

$$\phi_E = E \cdot A = \left(\frac{\sigma}{\epsilon_0} \right) \cdot A$$

$$I_d = \epsilon_0 \left(\frac{d\phi_E}{dt} \right) = \epsilon_0 \times \frac{d}{dt} \left[\left(\frac{\sigma}{\epsilon_0} \right) \times A \right]$$

$$= \epsilon_0 \cdot \frac{A}{\epsilon_0} \cdot \frac{d\sigma}{dt}$$

Since A and $\frac{d\sigma}{dt}$ are constant, the displacement current I_d is constant and uniform between the plates.

$$B = \frac{\mu_0 I_d}{2\pi r^2} \times r$$

So, B is zero at the center ($r = 0$) and increase linearly with r , reaching maximum at $r = R$

Outside ($r > R$)

$$\oint B \cdot dl = B \cdot (2\pi r)$$

$$I_d(\text{enclosed}) = I_d(\text{total displacement current})$$

$$B \times 2\pi r = \mu_0 \cdot I_d$$

$$B = \frac{\mu_0 I_d}{2\pi r}$$

So, B decreases as $\frac{1}{r}$ outside the plate.

Hence B is non-zero both inside and outside, rising to a maximum at $r = R$ (the cylindrical surface through the rims) and then decreasing. non-zero everywhere, maximum on the imaginary cylinder joining the plate peripheries.

Q27 Text Solution:

$$\tan \theta_B = n_2/n_1 = 1.73 \Rightarrow \theta_B \approx 60^\circ.$$

At Brewster's angle:

- incidence = reflection $\approx 60^\circ$ (air \rightarrow medium).
- reflected beam is **completely plane-polarised** (electric field \perp plane of incidence).
- angle of refraction (θ_r) : -

$$\theta_B + \theta_r = 90^\circ$$

$$\theta_r = 30^\circ(\text{partially polarised})$$

So, reflected light is fully polarised and the angle of reflection is $\sim 60^\circ$.

Q28 Text Solution:

After each contact identical spheres share charge equally.

1. When C touches A (q) \rightarrow each gets $q/2$.

$$Q_A = q/2, Q_C = q/2.$$

2. When C ($q/2$) touches B (q) \rightarrow each gets $\frac{3q}{4}$

$$Q_B = 3q/4, Q_C = 3q/4.$$

$$\text{Initial force } F = kq^2/r^2.$$

$$T_2 = \frac{p_2 V_2}{n_2 R} = \frac{2 \times 3}{4R} = 1.50 \frac{\text{L-atm}}{R}$$

$$T_f = \frac{n_1 T_1 + n_2 T_2}{n_1 + n_2} = \frac{5(0.40) + 4(1.50)}{9}$$

$$= 0.888 \frac{\text{L-atm}}{R}$$

$$V = 2 + 3 = 5 \text{ L}$$

$$P_f = \frac{nRT_f}{V} = \frac{9(0.888 R)}{5} = 1.6 \text{ atm}$$

Equilibrium pressure ≈ 1.6 atm.

Q30 Text Solution:

Centripetal balance with the constant inward force F :

$$\frac{mv^2}{r} = F \Rightarrow v = \sqrt{\frac{F}{m} r}.$$

$$mvr = \frac{nh}{2\pi}$$

$$m \left(\sqrt{F/m} r^{1/2} \right) r = \frac{nh}{2\pi}$$

$$\Rightarrow m \sqrt{F/m} r^{3/2} = \frac{nh}{2\pi} \Rightarrow r^{3/2} \propto n$$

$$\Rightarrow \boxed{r \propto n^{2/3}}.$$

$$\text{Then } v \propto \sqrt{r} \propto n^{1/3}.$$

Q31 Text Solution:

Kepler's third law: $T^2 \propto r^3$.

$$\left(\frac{T_{\text{Mars}}}{T_{\text{Mercury}}} \right)^2 = \left(\frac{r_{\text{Mars}}}{r_{\text{Mercury}}} \right)^3 = (4)^3 = 64$$

$$\Rightarrow T_{\text{Mercury}} = \frac{T_{\text{Mars}}}{8}.$$

$T_{\text{Mercury}} = 687/8 \approx 86$ days (nearest value 88 days).

Q32 Text Solution:

At height $h = \frac{R}{3}$ above Earth's surface the distance from Earth's centre is

$$r = R + h = R + \frac{R}{3} = \frac{4R}{3}.$$

Gravitational force varies as the inverse square of this distance:

$$R_p = \frac{R}{4} + \frac{R}{32}$$

Two such R_p are then in series

$$R_{\text{net}} = R_p + R_p = \frac{R}{32} + \frac{R}{32} = \frac{R}{16}$$

Q34 Text Solution:

$$r_n = n^2 a_0 \text{ with } a_0 = 0.052 \text{ nm.}$$

$$r_2 = 4a_0 = 4(0.052) = 0.208 \text{ nm.}$$

$$2\pi r_n = n\lambda:$$

$$\lambda = \frac{2\pi r_2}{n} = \frac{2\pi(0.208)}{2} \text{ nm} \approx 0.65 \text{ nm.}$$

Answer $\approx 0.67 \text{ nm.}$

Q35 Text Solution:

Potential energy of a dipole: $U = -pE \cos \theta.$

- initially ($\theta_i = 0^\circ$) $U_i = -pE$
- after rotation by 60°

$$U_f = -pE \cos 60^\circ = -\frac{1}{2}pE$$

$$\Delta U = U_f - U_i = -\frac{1}{2}pE - (-pE) = \frac{1}{2}pE$$

$$p = 5 \times 10^{-6} \text{ C-m, } E = 4 \times 10^5 \text{ N C}^{-1}$$

$$\Delta U = \frac{pE}{2} = \frac{(5 \times 10^{-6})(4 \times 10^5)}{2} = 1.0 \text{ J}$$

Q36 Text Solution:

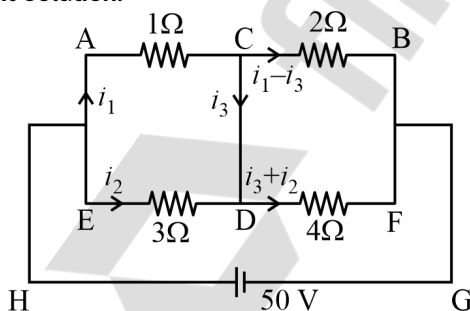

Consider loop ACDEA,

$$i_1 = 3i_2 \quad \dots(1)$$

Consider loop CBFDC,

$$3i_3 + 2i_2 - i_1 = 0 \quad \dots(2)$$

From (1)

$$i_2 = 3i_3 \quad \dots(1)$$

Electron (non-relativistic):

$$E = p^2/2m \Rightarrow p = \sqrt{2mE}, \lambda_e = \frac{h}{p}$$

$$= \frac{h}{\sqrt{2mE}}$$

$$\frac{\lambda_\gamma}{\lambda_e} = \frac{hc/E}{h/\sqrt{2mE}} = c\sqrt{\frac{2m}{E}}$$

Q38 Text Solution:

Photoelectric current depends on intensity of light as given

photoelectric current \propto intensity of light (for frequency of light above threshold frequency).

Q39 Text Solution:

Small cut sphere $m_s = \frac{4}{3}\pi R^3 \rho.$

Large sphere $M = \frac{4}{3}\pi(2R)^3 \rho = 8m_s.$

Remaining mass $m_r = 8m_s - m_s = 7m_s.$

Moments of inertia about Y-axis:

- Large sphere (axis through its centre):

$$I_L = \frac{2}{5}M(2R)^2 = \frac{64}{5}m_s R^2.$$

- Small sphere: centre is at distance $d = R$ from Y-axis.

$$I_s = \frac{2}{5}m_s R^2 + m_s d^2 = \frac{2}{5}m_s R^2 + m_s R^2$$

$$= \frac{7}{5}m_s R^2$$

- Remaining portion:

$$I_r = I_L - I_s = \left(\frac{64}{5} - \frac{7}{5}\right)m_s R^2.$$

$$= \frac{57}{5}m_s R^2$$

$$\frac{I_s}{I_r} = \frac{\frac{7}{5}}{\frac{57}{5}} = \frac{7}{57}.$$

Q40 Text Solution:

At $t = 15 \text{ ms,}$

$$V_{\text{in}} = 220 \sin(100\pi t) = 220 \sin(100\pi \times 0.015)$$

$$= 220 \sin(1.5\pi) = -220 \text{ V}$$

Negative half-cycle \Rightarrow the upper end of the secondary is $-$, the lower end is $+$.

internal energy changes:

$$Q_A = \Delta U + P\Delta V_A = Q_B = \Delta U + P\Delta V_B \implies \Delta V_A = \Delta V_B.$$

With a movable piston, $\Delta V = (\pi r^2) \Delta x$.

$$\pi r_A^2 (16 \text{ cm}) = \pi r_B^2 (9 \text{ cm})$$

$$\implies \frac{r_A^2}{r_B^2} = \frac{9}{16} \implies \frac{r_A}{r_B} = \frac{3}{4}$$

Q42 Text Solution:

Relative (percentage) error adds with the absolute value of the exponents:

$$\frac{\Delta P}{P} (\%) = 3(\Delta a\%) + 2(\Delta b\%) + 1(\Delta c\%) + \frac{1}{2}(\Delta d\%)$$

$$3(1) + 2(3) + 1(2) + \frac{1}{2}(4) = 3 + 6 + 2 + 2 = 13\%.$$

Q43 Text Solution:

First polaroid \rightarrow polarised light I_0 .

Middle sheet at 22.5° to this axis:

$$I_1 = I_0 \cos^2 22.5^\circ.$$

Second polaroid is crossed with the first, hence $90^\circ - 22.5^\circ = 67.5^\circ$ from the sheet's axis:

$$I_2 = I_1 \cos^2 67.5^\circ = I_0 \cos^2 22.5^\circ \sin^2 22.5^\circ.$$

$$\cos^2 \theta \sin^2 \theta = \frac{1}{4} \sin^2 2\theta; \quad \theta = 22.5^\circ \implies 2\theta = 45^\circ, \quad \sin 45^\circ = \frac{1}{\sqrt{2}}$$

$$I_2 = \frac{I_0}{4} \left(\frac{1}{\sqrt{2}} \right)^2 = \frac{I_0}{4} \left(\frac{1}{2} \right) = \frac{I_0}{8}.$$

Transmitted intensity = $I_0/8$.

Q44 Text Solution:

Maximum speed in SHM:

$$v_{\max} = \omega A = \sqrt{\frac{k}{m}} A.$$

Equal masses m ; equal v_{\max} :

$$\sqrt{\frac{k_1}{m}} A_P = \sqrt{\frac{k_2}{m}} A_Q \implies \frac{A_Q}{A_P} = \sqrt{\frac{k_1}{k_2}}.$$

Half-submerged \rightarrow the air column has length $L/2$ now with the water surface acting as a closed end \implies open-closed pipe.

New fundamental frequency:

$$f' = \frac{v}{4(L/2)} = \frac{v}{2L} = f.$$

Fundamental frequency remains f .

Q46 Text Solution:

For hydrogen,

$E_n = -R_H/n^2$. Absorbed photon energy is

$\Delta E = R_H(1/n_1^2 - 1/n_2^2)$. Thus

$2 \rightarrow 3: \Delta E_1 = R_H \cdot 5/36; \quad 4 \rightarrow 6:$

$\Delta E_2 = R_H \cdot 5/144.$

Since $\lambda \propto 1/\Delta E$,

$\lambda_1/\lambda_2 = \Delta E_2/\Delta E_1 = 1/4$. Hence option 4 is the correct answer.

Q47 Text Solution:

Electronegativity of N and Cl is equal (3.0, so B false.

Gallium melts at 29.8°C , close to Cs 28.5°C ; A false.

Ar, K^+ , Cl^- , Ca^{2+} , S^{2-} all have $18e^-$, hence C true. radius $\text{Cs} > \text{Rb} > \text{Li}$; E true.

First-IE trend is $\text{Si} > \text{Mg} > \text{Al} > \text{Na}$, so D false.

Q48 Text Solution:

Group number in cation analysis

Group I	Pb^{2+}
Group III	Al^{3+} , Fe^{3+}
Group IV	Cu^{2+} , Ni^{2+} , Zn^{2+}
Group VI	Mg^{2+}

Q49 Text Solution:

total energy

$$E_n = -R_H Z^2/n^2 \text{ and}$$

orbit radius

$$r_n = a_0 n^2/Z$$

For $n = 1$, He^+ ($Z = 2$) gives

$$E = -8.72 \times 10^{-18} \text{ J and } r = 26.4 \text{ pm,}$$

while Li^{2+} ($Z = 3$) gives

$$E = -19.62 \times 10^{-18} \text{ J and } r = 17.6 \text{ pm.}$$

Q51 Text Solution:

Cl^- and H_2O are weak-field; Ni^{2+} (d^8) therefore remains high-spin: $[\text{NiCl}_4]^{2-}$ is tetrahedral, $[\text{Ni}(\text{H}_2\text{O})_6]^{2+}$ octahedral, each retaining two unpaired electrons and hence paramagnetic. CO and PPh_3 give $\text{Ni}(\text{O}) d^{10}$ ($\text{Ni}(\text{CO})_4$, $\text{Ni}(\text{PPh}_3)_4$) \Rightarrow diamagnetic. Strong-field CN^- forces square-planar low-spin d^8 in $[\text{Ni}(\text{CN})_4]^{2-}$, also diamagnetic. Thus only A and D are clearly paramagnetic.

Q52 Text Solution:

- All the elements of group 15 form hydrides of the type EH_3 where $\text{E} = \text{N, P, As, Sb or Br}$.
- All the elements of group-15 form two type of oxides: E_2O_3 and E_2O_5

Q53 Text Solution:

Main group=elements whose valence shell involves only s or p subshells (Groups 1–2, 13–18). Configuration A ($[\text{Ne}] 3s^1$) corresponds to Na, an s-block metal; configuration C ($[\text{Kr}] 4d^{10} 5s^2 5p^5$) is I, a p-block halogen. Configurations B and D possess 3d electrons, and E (Th) has 6d/5f involvement, so none are main-group. Therefore the only main-group configurations listed are A and C, making Option 2 the correct choice.

Q54 Text Solution:

Dalton's theory could explain the laws of chemical combinations. However, it could not explain the laws of gaseous volumes.

$$Kt = 2.303 \log \frac{a}{a-x}$$

$$\frac{0.693}{t_{1/2}} \times t = 2.303 \log \frac{100}{100-99.9}$$

$$\frac{0.693}{1} \times t = 2.303 \log \frac{100}{0.1}$$

$$t = \frac{2.303}{0.693} \log 10^3$$

$$t = \frac{2.303}{0.693} \times 3 \log 10$$

$$t = 10 \text{ min}$$

Q57 Text Solution:

The crystal field splitting Δ_0 , depends upon the field produced by the ligand and charge on the metal ion.

Ligand can be arranged in the increasing field strength Δ_0 as given below:



A higher charge on the metal ion leads to a large splitting and a higher Δ_0 .

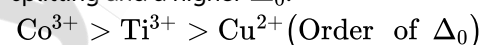

$$\lambda \text{ absorbed} \propto \frac{1}{\Delta_0}$$

Sequence of wavelength

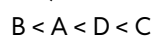

Q58 Text Solution:

Geometric (cis-trans) isomerism requires restricted rotation and two different substituents on each stereogenic centre. Pent-1-ene and 2-methylhex-2-ene possess identical groups on one carbon. 1,1-Dimethylcyclopropane holds both methyls on the same carbon. In 1,2-Dimethylcyclohexane C-1 and C-2 can occupy the same or opposite faces, producing distinct cis- and trans-isomers.

Q59 Text Solution:

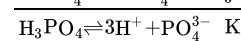
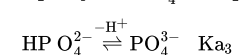
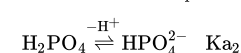
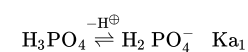

$$K = K_{a1} \times K_{a2} \times K_{a3}$$

$$(A) \log K = \log K_{a1} + \log K_{a2} + \log K_{a3}$$

charged ion Hence, A, B and C are correct.

Q60 Text Solution:

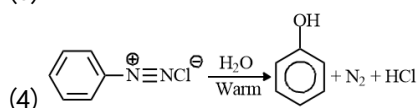
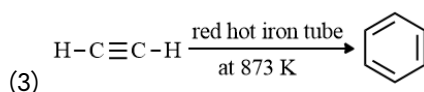
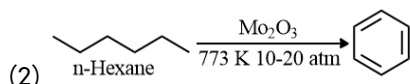
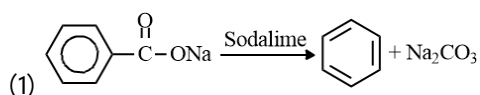

Q61 Text Solution:

For weak electrolytes, degree of dissociation $\alpha = \Lambda_m / \Lambda_m^0$. The limiting molar conductivity of the monobasic acid is $\Lambda_m^0 = \Lambda_+^0 + \Lambda_-^0 = 349.6 + 50.4 = 400.0 \text{ Scm}^2 \text{ mol}^{-2}$. With observed $\Lambda_m = 90 \text{ S cm}^2 \text{ mol}^{-1}$ at 0.050 M $\alpha = \frac{90}{400} = 0.225$

Q62 Text Solution:

A stable molecule can not have zero bond order. A bond order of zero indicates that the molecule does not exist hence statement 1 is false. As bond order increases, bond length decreases because bond length and bond order are inversely related. Hence statement 2 is also false.

Q63 Text Solution:

Since conductance is directly proportional to the number of ions, the compound that produces the least number of ions will have the minimum conductance. Option 1 and 2 forms an overall neutral complex: no counte ions are released in water. So these will contain minimum conductance in solution.

Q64 Text Solution:

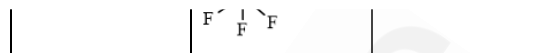
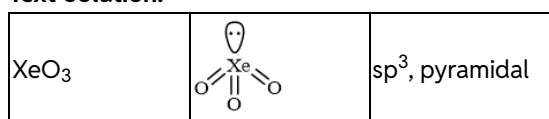

Q65 Text Solution:

Formation of CH₄ from graphite and H₂ is an exothermic reaction ($\Delta H = -74.8 \text{ kJ mol}^{-1}$). Therefore products must lie 74.8 kJ below reactants; the energy diagram should display an activation-energy peak and then a lower product plateau, with a downward vertical arrow labelled 74.8 kJ connecting reactants to products. Only diagram 1 depicts all these features accurately.

Q66 Text Solution:

Humidity is water vapour in air, a liquid-in-gas system. Alloys are homogeneous metallic mixtures, classified as solid-in-solid solutions. Amalgams contain liquid mercury dissolved in a solid metal, giving liquid-in-solid dispersions. Smoke comprises fine solid particles suspended in air, hence solid-in-gas. Thus the correct sequence is A-II, B-I, C-IV, D-III.

Q67 Text Solution:

Aliphatic amines are stronger bases than aromatic amines because the lone pair on N is localised. Among aliphatic amines, greater +I and hyperconjugation raise electron density: secondary (-N(Et)₂) > primary (-NH₂). In anilines, conjugation with the benzene ring withdraws electron density; a methyl group slightly offsets this, so N-methylaniline > aniline. Thus N-ethylethanamine > ethanamine > N-methylaniline > benzenamine.

Q68 Text Solution:

Moles present: Na₂CO₃ = 212 ÷ 106 = 2 mol;
Na₂O = 248 ÷ 62 = 4 mol; NaOH = 240 ÷ 40 = 6 mol;
H₂ = 12 ÷ 2 = 6 mol; CO₂ = 220 ÷ 44 = 5 mol.
Total atoms = moles × N_A × atomicity
Na₂CO₃ → 2 mol × 6 = 12 N_A;
Na₂O → 4 mol × 3 = 12 N_A; H₂ → 6 mol × 2 = 12 N_A;
NaOH → 6 mol × 3 = 18 N_A; CO₂ → 5 mol × 3 = 15 N_A

Alkyl groups exert a +I effect that destabilises the carboxylate anion, lowering acidity. Formic acid (no alkyl) is strongest, followed by acetic acid (one CH₃). Isobutyric acid bears two methyl groups, pivalic acid three, giving progressively weaker acids. Hence the order is HCOOH > CH₃COOH > (CH₃)₂CHCOOH > (CH₃)₃CCOOH.

Q71 Text Solution:

Ferromagnetism arises when unpaired spins align parallel throughout a solid and it is an extreme form of paramagnetism, so Statement I is correct. Cr²⁺ has configuration [Ar] 3d⁴ with four unpaired electrons, while Nd³⁺ is [Xe] 4f³ with three unpaired electrons, so their counts differ; Statement II is incorrect.

Q72 Text Solution:

- Simple distillation separates chloroform (61°C)/aniline because of their wide boiling gap.
- Crude oil in petroleum industry is fractionated by fractional distillation.
- High-boiling glycerol is obtained from spent-lye via distillation under reduced pressure.
- Aniline becomes steam-volatile, so aniline-water is removed by steam distillation.

Q73 Text Solution:

For the elementary reversible reaction $A \rightleftharpoons 2B$, the equilibrium constant in concentration units is the ratio of rate constants:

$$K_c = k_f/k_b = 1/2500 = 4.0 \times 10^{-4}$$

$$\text{Because } \Delta n_g = (2-1) = 1, K_p = K_c (RT)^{\Delta n_g}$$

$$\text{At } 1000 \text{ K, } RT = 0.0831 \times 1000 = 83.1$$

$$\text{Thus } K_p = 4.0 \times 10^{-4} \times 83.1 \approx 0.033$$

Q74 Text Solution:

Diazotization: aniline + nitrous acid at 273–278 K yields highly unstable benzenediazonium chloride; the dry salt can explode, so Statement I

0–5°C

Q75 Text Solution:

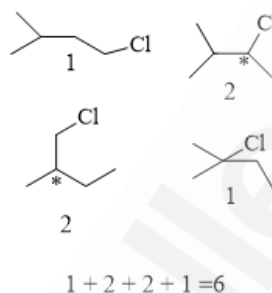

Q76 Text Solution:

Acetylenic C–H (sp, 50 % s-character) holds electron density closest to the nucleus, giving the strongest σ -bond and the highest bond-dissociation energy. Aryl C–H (sp², 33 % s) is weaker. Cyclopropane carbon is effectively sp³ (25 % s); ring strain adds little, so its C–H bond is the weakest.

Q77 Text Solution:

Bromine water is decolourised by compounds that undergo electrophilic addition to the C=C bond or rapid electrophilic substitution on an activated aromatic ring. Phenol and aniline activate the ring toward Br₂, while styrene's vinyl double bond adds Br₂. Saturated cyclohexane lacks both unsaturation and ring activation, so it fails to decolourise bromine water.

Q78 Text Solution:

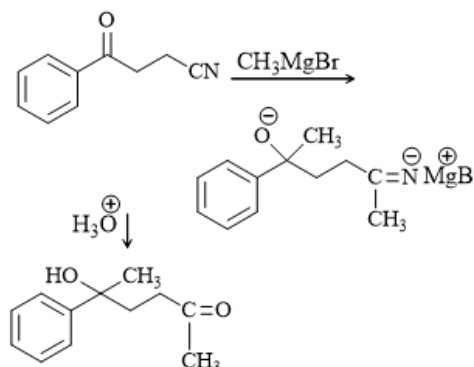

Q79 Text Solution:

Haber process uses finely divided Fe catalyst.
Wacker oxidation converts alkenes to aldehydes with $\text{PdCl}_2/\text{CuCl}_2$.

Wilkinson catalyst, $[(\text{PPh}_3)_3\text{RhCl}]$, enables homogeneous hydrogenation.

Ziegler–Natta polymerisation employs TiCl_4 partnered with $\text{Al}(\text{CH}_3)_3$.

A - I

B - II

C - III

D - IV

Q81 Text Solution:

Raoult's law predicts

$$P_{\text{ideal}} = \chi_x P_x^\circ + \chi_y P_y^\circ$$

$$= \frac{5}{15} \times 63 + \frac{10}{15} \times 78 = 73 \text{ torr}$$

Measured pressure = 70 torr which is lower than ideal. A reduced vapour pressure signals stronger X-Y attraction than like-like interactions, giving a negative deviation from ideality.

Q82 Text Solution:

Natural honey contains equal amounts of D-glucose and D-fructose; the latter is a ketohexose, hence a keto-sugar. In aqueous solution it cyclises to fructofuranose and fructopyranose, giving α - and β -anomeric pairs. The specific rotation of D-fructose is -92° , making it laevorotatory.

Q83 Text Solution:

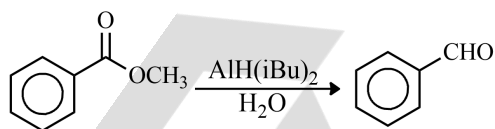

LiAlH_4 furnishes alcohol, NaBH_4 fails with esters, and Rosenmund reduction ($\text{H}_2/\text{Pd}-\text{BaSO}_4$) works only on acid chlorides, not esters.

Q84 Text Solution:

Rate of $\text{S}_\text{N}2$ reaction depends on leaving group tendency. 1-Iodobutane reacts faster than 1-chlorobutane because I^- leaves more readily.

$$[\text{SO}_4^{2-}(\text{aq})] + \Delta H^\circ_{\text{crys.}}$$

$$-349 = \Delta H^\circ_f [\text{Ba}^{2+}] + (-216) + (-4.5)$$

$$\Rightarrow \Delta H^\circ_f [\text{Ba}^{2+}] = -128.5 \text{ kcal mol}^{-1}$$

Q86 Text Solution:

Cyclic-ether skeletons for $\text{C}_4\text{H}_8\text{O}$ are:

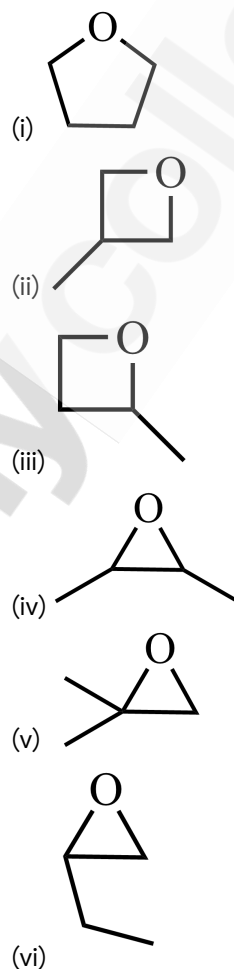

Total stereochemical variants: $1+1+2+3+1+2=10$ isomers.

Q87 Text Solution:

- Dipole moments: $\text{H}_2\text{O} (1.85 \text{ D}) > \text{NH}_3 (1.47 \text{ D}) > \text{CHCl}_3 (\approx 1.04 \text{ D})$, so A is true.
- Lone-pair counts: $\text{XeF}_2 (3) > \text{XeF}_4 (2) > \text{XeO}_3 (1)$, opposite to B, so B is false.
- Bond lengths: $\text{O}-\text{H} (96 \text{ pm}) < \text{C}-\text{H} (110 \text{ pm}) < \text{N}-$

also predicts that increasing the concentration of either reactant (N_2 or O_2) drives the equilibrium forward to re-establish balance. Lower temperature would favour the exothermic reverse step, giving less NO .

Q89 Text Solution:

For a first-order reaction $k = 0.03 \text{ s}^{-1}$ and

$$t = \frac{2.303}{k} \log \frac{[R]_0}{[R]}$$

Initial $[R]_0 = 7.2 \text{ mol L}^{-1}$; final

$[R] = 0.9 \text{ mol L}^{-1}$.

$$\frac{[R]_0}{[R]} = 8;$$

$$\log 8 = 3 \log 2 = 3(0.301) = 0.903.$$

$$t = \frac{2.303}{0.03} \times 0.903 \approx 69.3 \text{ s}.$$

Q90 Text Solution:

Lassaigne fusion converts hetero-atoms of an organic compound into water-soluble sodium salts: $NaCN$ for $C+N$, Na_2S for S , and NaX for halogens, enabling their qualitative detection. The CuO -carbon reduction is a metallurgical reaction, unrelated to the sodium-fusion method; hence it is excluded from Lassaigne's test.

Q91 Text Solution:

Complex II of the mitochondrial electron transport chain is known as Succinate dehydrogenase. It catalyzes the oxidation of succinate to fumarate in the Krebs cycle and transfers electrons to ubiquinone (coenzyme Q).

Q92 Text Solution:

In Polymerase chain reaction, each cycle of amplification **doubles** the amount of DNA. So, if we start with one molecule of DNA, after:

- 1 cycle \rightarrow 2 molecules
- 2 cycles \rightarrow 4 molecules

Q93 Text Solution:

The potential drawbacks in adoption of the *in-vitro* fertilisation methods are;

1. Expensive instruments and reagents as the assisted reproductive techniques require extremely high precision handling by specialised professionals and expensive instrumentation.
2. Less adoption of orphans as in India we have so many orphaned and destitute children, who would probably not survive till maturity, unless taken care of. The *in-vitro* fertilisation methods reduce the chances of legal adoption of orphan children.

There is always a possibility that early embryos formed by *in-vitro* fertilisation methods do not survive.

Q94 Text Solution:

The blood from the heart of frog is carried to all the parts of the body through the arteries and the veins collect deoxygenated blood from the different parts of the body to the heart of frog. Therefore the correct answer is venacava.

Q95 Text Solution:

Reductionist Biology seeks to understand living systems by studying their molecular, physical, and chemical properties. It explains biological functions in terms of the interactions of molecules and biophysical processes.

Q96 Text Solution:

RNA was the first genetic material. RNA used to act as a genetic material as well as a catalyst (there are some important biochemical reactions in living systems that are catalysed by RNA catalysts and not by protein enzymes). But, RNA being a catalyst was reactive and hence unstable. DNA has evolved from RNA with chemical

support and access to sunlight, while the mango tree is unaffected. This is a classic example of commensalism.

Q98 Text Solution:

- **A.** ✓ True — Eukaryotic ribosomes are **80S**, and prokaryotic ribosomes are **70S**.
- **B.** ✓ True — Each ribosome consists of **two subunits**.
- **C.** ✓ True — 80S ribosome = **60S + 40S**, and 70S ribosome = **50S + 30S**.
- **D.** ✗ Incorrect — 20S is not a known subunit of ribosomes.
- **E.** ✗ Incorrect — 80S subunits are **60S and 40S**, not 60S and 30S.

Q99 Text Solution:

Ex-situ conservation involves protecting an endangered species by removing part of the population from a threatened habitat and placing it in a new location. Zoos and botanical gardens are prime examples, where organisms are conserved outside their natural habitat.

Q100 Text Solution:

Statement I is correct- Solar energy is the primary source of energy in an ecosystem. Statement II is incorrect- The rate of production of organic matter during photosynthesis is gross primary productivity.

Q101 Text Solution:

Emphysema – Damaged alveolar walls and decreased respiratory surface
 Angina pectoris – Acute chest pain when not enough oxygen is reaching to heart muscle
 Glomerulonephritis – Inflammation of glomeruli of kidney

chance factor. To compensate for this, flowers produce a large number of pollen grains compared to the number of ovules.

But reason is not a correct explanation of assertion.

Q103 Text Solution:

Wine and beer are produced without distillation whereas whisky, brandy and rum are produced by distillation of the fermented broth.

Q104 Text Solution:

Statement I is incorrect while statement II is correct.

⊕ for actinomorphic and % for zygomorphic nature of flower. \underline{G} for superior ovary and \overline{G} for inferior ovary.

Q105 Text Solution:

Streptokinase produced by the bacterium *Streptococcus* is used as a 'clot buster' for removing clots from the blood vessels of patients who have undergone myocardial infarction leading to heart attack.

Q106 Text Solution:

Chromosome 1 has most genes (2968), and the Y has the fewest (231).

Q107 Text Solution:

Male frogs can be distinguished from the female frog by the presence of copulatory pad on the first digit of the fore limbs. This structure helps the male hold onto the female during reproduction.

Q108 Text Solution:

Cytokinins promote nutrient mobilisation which helps in the delay of leaf senescence.

Q109 Text Solution:

In certain animals, the body cavity is not fully lined by mesoderm. Instead, the mesoderm exists as scattered pouches between the ectoderm and endoderm and generally the mesoderm lines

Acrosome	Enzyme
Tail	Sperm motility

Q111 Text Solution:

In pteridophytes, the main plant body is a sporophyte which is differentiated into true root, stem and leaves. The sporophytes bear sporangia that are subtended by leaf-like appendages called sporophylls. The sporangia produce spores by meiosis in spore mother cells. The spores germinate to give rise to inconspicuous, small but multicellular, free-living, mostly photosynthetic thalloid gametophytes called prothallus. The gametophytes bear male and female sex organs called antheridia and archegonia, respectively. Water is required for transfer of antherozoids – the male gametes released from the antheridia, to the mouth of archegonium. Fusion of male gamete with the egg present in the archegonium result in the formation of zygote. Zygote thereafter produces a multicellular well-differentiated sporophyte which is the dominant phase of the pteridophytes.

Q112 Text Solution:

Cardiac activities of heart are regulated by

- Nodal tissue- SA node (sinoatrial node): pacemaker, AV node (atrioventricular node), Bundle of His and Purkinje fibers.
- A Special tissue in the medulla oblongata.
- Adrenal medullary hormone- Adrenaline and nor-adrenaline

Q113 Text Solution:

The nodules on the roots of leguminous plants are formed by the symbiotic association of *Rhizobium*. These bacteria fix atmospheric nitrogen into organic forms, which is used by the plant as nutrient. Other bacteria can fix atmospheric nitrogen while free-living in the soil (examples *Azospirillum* and *Azotobacter*), thus enriching

rRNA is part of the ribosome and helps in aligning mRNA and tRNA, facilitating protein synthesis.

RNA interference (RNAi) takes place in all eukaryotic organisms as a method of cellular defence.

Q115 Text Solution:

In insertional inactivation process, a recombinant DNA is inserted into the β -galactosidase gene, which inactivates the enzyme.

- When no insert is present, the enzyme works, and colonies turn blue due to a chromogenic substrate.
- When the insert is present, the enzyme is inactivated, and white(no colour) appears, identifying the colonies as recombinant.

Q116 Text Solution:

Eli Lilly, a pharmaceutical company, was the first to commercialise genetically engineered human insulin under the brand name Humulin. Scientists inserted the human insulin gene into plasmids, which were then introduced into genetically engineered *Escherichia coli* bacteria (a type of bacterium).

Q117 Text Solution:

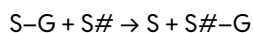

Where:

- G is a group other than hydrogen,
- S and S# are substrates.

The transfer of a functional group (G) from one molecule (S) to another (S#).

Such reactions are catalyzed by Transferases, which are enzymes that transfer functional groups from one molecule to another.

Q118 Text Solution:

In a monocot stem,

Q119 Text Solution:

The correct sequence of events in the life cycle of bryophytes is:

- B: Attachment of gametophyte to substratum
- E: Release of antherozoids into water
- A: Fusion of antherozoid with egg
- D: Formation of sporophyte
- C: Reduction division to produce haploid spores

This sequence reflects the alternation of generations in bryophytes, where the dominant gametophyte generation gives rise to the sporophyte after fertilization.

Q120 Text Solution:

Computed tomography and magnetic resonance imaging detect cancers of internal organs. Several chemotherapeutic drugs are used to kill cancerous cells. The patients are given substances called biological response modifiers such as α -interferon which activates their immune system and helps in destroying the tumor. Increased cell counts are found in the case of leukemias.

Q121 Text Solution:

A.	Centromere	II.	Cell division (site where spindle fibres attach during mitosis)
B.	Cilium	III.	Cell movement (helps in locomotion or movement of substances)
C.	Cristae	I.	Mitochondrion (infoldings of the inner mitochondrial membrane)

leaves is not due to a single pigment but due to four pigments:

- Chlorophyll a (bright or blue green in the chromatogram), chlorophyll b (yellow green), xanthophylls (yellow) and carotenoids (yellow to yellow-orange).
- These pigments are involved in capturing light energy during photosynthesis, and each has a characteristic colour based on its light absorption spectrum.

Q123 Text Solution:

By the end of 12 weeks (first trimester), most of the major organ systems are formed.

Q124 Text Solution:

In the seeds of cereals such as maize the seed coat is membranous and generally fused with the fruit wall. The endosperm is bulky and stores food. The outer covering of endosperm separates the embryo by a proteinous layer called aleurone layer.

Q125 Text Solution:

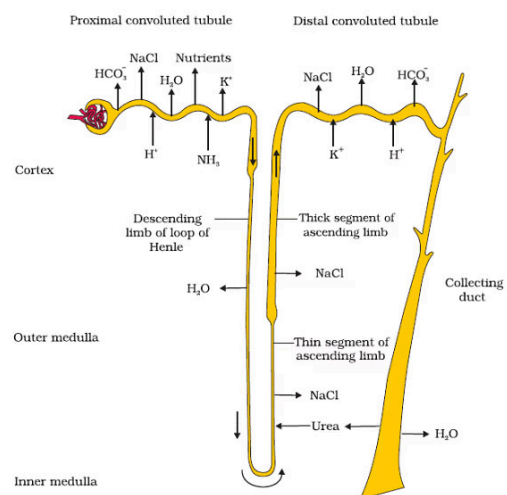

Q126 Text Solution:

Q127 Text Solution:

- Assertion (A) is true: A mature angiosperm embryo sac is 8-nucleate and 7-celled (3 antipodals, 2 synergids, 1 egg cell, and 1 central cell with 2 polar nuclei).
- Reason (R) is false: The egg apparatus contains 1 egg cell and 2 synergids, not 2 polar nuclei. The 2 polar nuclei are present in the central cell, not the egg apparatus.

Q128 Text Solution:

Mesosomes are specialized infoldings of the plasma membrane in prokaryotic cells. They assist in:

- Cell wall formation
- DNA replication
- Respiration

Q129 Text Solution:

The post-transcriptional events in a eukaryotic cell include:

- B. Removal of introns and joining of exons (splicing)
- C. Addition of a methyl guanosine cap at the 5' end of hnRNA (capping)
- D. Addition of adenine residues at the 3' end (poly-A tailing)

A is incorrect because transport to cytoplasm occurs after splicing, and E (base pairing of two complementary RNAs) is not a typical post-transcriptional modification.

Q130 Text Solution:

Polygenic traits are controlled by multiple genes, each contributing a small additive effect. These traits do not follow Mendel's laws of inheritance and exhibit continuous variation (e.g., skin color,

Q132 Text Solution:

Explanation (Increasing order of body complexity based on Whittaker's 5 Kingdom classification):

- C. Prokaryotes with cell wall (Kingdom Monera) – simplest
- E. Eukaryotes with cellular body organization (Kingdom Protista)
- A. Multicellular heterotrophs with chitinous cell wall (Kingdom Fungi)
- D. Eukaryotic autotrophs with tissue/organ level (Kingdom Plantae)
- B. Heterotrophs with tissue/organ/organ system (Kingdom Animalia) – most complex

This sequence reflects increasing levels of structural and functional complexity.

Q133 Text Solution:

Ramdeo Misra is regarded as the Father of Ecology in India for his pioneering work in the field of ecology and environmental science, especially ecosystem analysis and conservation biology.

Q134 Text Solution:

A.	Alfred Hershey and Martha Chase	IV.	DNA as genetic material confirmation
B.	Euchromatin	III.	Loosely packed and light-stained
C.	Frederick Griffith	I.	<i>Streptococcus pneumoniae</i>
D.	Heterochromatin	II.	Densely packed and dark-stained

Q135 Text Solution:

The malignant tumors are a mass of proliferating cells called neoplastic or tumor cells. These cells grow very rapidly, invading and damaging the surrounding normal tissues.

construction of recombinant DNA molecules by joining them with cloning vectors.

- Since DNA fragments are negatively charged molecules, therefore they can be separated by forcing them to move towards the anode under an electric field through a medium/matrix.
- The DNA fragments separate according to their size through sieving effect provided by the agarose gel. Hence, the smaller the fragment size, the farther it moves.
- Therefore, smaller fragments will be observed at the anode whereas the larger DNA fragments near the wells in agarose gel.

Q137 Text Solution:

List -I	List -II
Adenosine	Nucleoside
Adenylic acid	Nucleotide
Adenine	Nitrogenous base
Alanine	Amino acid

Q138 Text Solution:

- The reduction division for the human female gametogenesis starts earlier than that of male gametogenesis as in females the reduction division is started before the birth of female baby.i.e., during the embryonic stages whereas in males, spermatogenesis begins at puberty.
- The gap between the first meiotic division and second meiotic division is much shorter for males as compared to females because in females, oogonia cells start division during embryonic stages and enter into prophase-I of the meiotic division and get temporarily arrested at that stage, called primary oocytes.
- Once puberty is attained in females, the primary oocytes complete prophase-I of first meiotic division to form secondary oocytes.
- The first meiotic division in females is an unequal division resulting in the formation of a

All living members of the class Cyclostomata are ectoparasites on some fishes.

Q140 Text Solution:

- Assertion (A): True – The Golgi apparatus functions to package and sort materials from the ER and delivers them to various destinations.
- Reason (R): True – Vesicles from the endoplasmic reticulum fuse with the cis face of the Golgi, and after processing, materials are released from the trans face.

Q141 Text Solution:

- A. Scutellum – II. Cotyledon of monocot seed
- B. Non-albuminous seed – III. Groundnut (no residual endosperm)
- C. Epiblast – IV. Rudimentary cotyledon (found in monocots)
- D. Perisperm – I. Persistent nucellus (e.g., in black pepper, beet)

Q142 Text Solution:

The members of subphylum Vertebrata possess notochord during the embryonic period. The notochord is replaced by a cartilaginous or bony vertebral column in the adult. Thus all vertebrates are chordates but all chordates are not vertebrates.

Q143 Text Solution:

- Each antibody molecule has four peptide chains, two small called light chains and two longer called heavy chains.
- The antigen binding site is present at the N-terminal region of the antibody molecule.
- Constant regions of heavy and light chains are located at the C-terminal of the antibody molecule.

Q144 Text Solution:

Q145 Text Solution:

When RRY_Y (round yellow) is crossed with rryy (wrinkled green), the F₁ hybrids (RrYy) are all round yellow. Selfing of the F₁ results in F₂ with phenotypic ratio of 9 round yellow : 3 round green : 3 wrinkled yellow : 1 wrinkled green.

Q146 Text Solution:

Histones are rich in lysine and arginine.

Q147 Text Solution:

The first menstruation in females begins at puberty and is called menarche.

Q148 Text Solution:

Heart – Atrial natriuretic factor
 kidney – Erythropoietin
 Gastro-intestinal tract – Secretin
 Adrenal Cortex – Aldosterone

Q149 Text Solution:

The protein portion of the enzyme is called the apoenzyme.

Q150 Text Solution:

Productivity is expressed in terms of gm⁻² yr⁻¹ or (kcal m⁻²) yr⁻¹.

Q151 Text Solution:

Potato is a stem modification (tuber) while Sweet potato is a root modification (root tuber). Both store food and perform similar functions, but have different origins. This means they are analogous organs (similar function, different origin), which arises due to Convergent evolution i.e. unrelated organisms independently evolve similar traits as a result of having to adapt to similar environments or ecological niches.

Q152 Text Solution:

This pedigree shows an X-linked recessive disorder:

- Females with one mutant allele (X^cX) are carriers.

Possible gametes from carrier female X^cX are having: X^c and Y

	X ^c	X
X ^c	X ^c X ^c	X ^c X
Y	X ^c Y	XY

Possible offspring in F₃ generation;

- X^cX^c → unaffected female
- X^cX → carrier female
- XY → unaffected male
- X^cY → affected male

Out of 4, only 1 child (X^cX) is a carrier and unaffected.

So, the probability = 1/4

Q153 Text Solution:

Assertion is true- Cells of the tapetum possess dense cytoplasm and generally have more than one nucleus.

But reason is false- The innermost wall layer is the tapetum which nourishes the developing pollen grains.

Q154 Text Solution:

Megasporogenesis : The process of formation of megaspores from the megaspore mother cell is called megasporogenesis. Ovules generally differentiate a single megaspore mother cell (MMC) in the micropylar region of the nucellus. It is a large cell containing dense cytoplasm and a prominent nucleus. The MMC undergoes meiotic division. In a majority of flowering plants, one of the megaspores is functional while the other three degenerate. Only the functional megaspore develops into the female gametophyte (embryo sac). The nucleus of the functional megaspore divides mitotically to form two nuclei which move to the opposite poles, forming the 2-nucleate embryo sac. Two more sequential mitotic nuclear divisions result in the

actinomorphic, e.g., mustard, *datura*, chilli. When it can be divided into two similar halves only in one particular vertical plane, it is zygomorphic, e.g., pea, gulmohur, bean, *Cassia*.

Q156 Text Solution:

Primary lymphoid organs: Bone marrow and thymus are the sites where **immature lymphocytes differentiate into antigen-sensitive lymphocytes**.

After maturation, lymphocytes **migrate to secondary lymphoid organs like** Spleen, Lymph nodes, Tonsils, Peyer's patches (small intestine), Appendix

Secondary organs are the **sites of antigen-lymphocyte interaction**. On encountering an antigen, lymphocytes **proliferate and form effector cells**.

Q157 Text Solution:

In many species of fig trees, there is a tight one-to-one relationship with the pollinator species of wasp. It means that a given fig species can be pollinated only by its 'partner' wasp species and no other species. Fig flower is pollinated by wasp. Wasp lays eggs in a fig fruit. The female wasp uses the fruit not only as an oviposition (egg-laying) site but uses the developing seeds within the fruit for nourishing its larvae. The wasp pollinates the fig inflorescence while searching for suitable egg-laying sites. In return for the favour of pollination the fig offers the wasp some of its developing seeds, as food for the developing wasp larvae.

Q158 Text Solution:

Small disc-shaped structures at the surface of the centromeres are called kinetochores. These structures serve as the sites of attachment of spindle fibres to the chromosomes. At the onset of anaphase, each chromosome arranged at the metaphase plate is split simultaneously and the

enclosed by any ovary wall and remain exposed, both before and after fertilisation. The seeds that develop post-fertilisation, are not covered, i.e., are naked.

Q160 Text Solution:

Adrenal medullary hormone are adrenaline and nor-adrenaline it causes pupillary dilation, hyperglycemia, piloerection(erection of hair) and increase strength of heart contraction

Q161 Text Solution:

Insulin is a protein hormone, and when taken orally, it gets broken down by digestive enzymes in the stomach and small intestine, just like any other dietary protein. As a result, it loses its structure and function before it can enter the bloodstream.

To ensure it works properly, insulin is given through injections, allowing it to directly enter the bloodstream and perform its function of regulating glucose levels in diabetic patients.

Q162 Text Solution:

Salvia is an angiosperm. *Ginkgo* is a gymnosperm. *Polytrichum* is a moss (bryophyte). *Salvinia* is a pteridophyte.

Q163 Text Solution:

It was George Gamow, a physicist, who argued that since there are only 4 bases and if they have to code for 20 amino acids, the code should constitute a combination of bases. He suggested that in order to code for all the 20 amino acids, the code should be made up of three nucleotides. This was a very bold proposition, because a permutation combination of 43 ($4 \times 4 \times 4$) would generate 64 codons; generating many more codons than required.

Q164 Text Solution:

- Causes of biodiversity losses: The accelerated rates of species extinctions that the world is

cryopreservation techniques.

- Familiar with the environmental damage caused and threat posed to our native species by invasive weed species like carrot grass (*Parthenium*), *Lantana* and water hyacinth (*Eicchornia*).
- Some examples of recent extinctions include the dodo (Mauritius), quagga (Africa), thylacine (Australia), Steller's Sea Cow (Russia).

Q165 Text Solution:

Neurohypophysis (pars nervosa) also known as posterior pituitary, stores and releases two hormones called oxytocin and vasopressin (anti-diuretic hormone), which are actually synthesised by the hypothalamus and are transported axonally to neurohypophysis.

Q166 Text Solution:

The most distinctive feature of echinoderms is the presence of water vascular system which helps in locomotion, capture and transport of food and respiration.

Q167 Text Solution:

Innate immunity is non-specific type of defence, that is present at the time of birth.

Q168 Text Solution:

Asexual reproduction in liverworts takes place by fragmentation of thalli, or by the formation of specialised structures called gemmae (sing. gemma). Gemmae are green, multicellular, asexual buds, which develop in small receptacles called gemma cups located on the thalli. The gemmae become detached from the parent body and germinate to form new individuals.

Q169 Text Solution:

Special venous connection between the kidney and lower parts of the body is present in frogs. This is called renal portal system.

Q170 Text Solution:

carboxylation of RuBP. This reaction is catalysed by the enzyme RuBP carboxylase which results in the formation of two molecules of 3-PGA. Since this enzyme also has an oxygenation activity it would be more correct to call it RuBP carboxylase-oxygenase or RuBisCO. RuBisCO has a much greater affinity for CO₂ when the CO₂: O₂ is nearly equal

Q172 Text Solution:

The enzymes essential for gene cloning are:
 Restriction enzyme - It recognises a specific sequence of nucleotides in double stranded DNA and cuts the DNA at a specific location.
 DNA ligase - They join broken pieces of DNA strand together during DNA replication.
 DNA polymerase - They function by replicating DNA by synthesizing new DNA strands using existing DNA strands as templates.

DNA mutase and DNA recombinase are not essential for gene cloning. As DNA mutase are enzymes that catalyse the movement of a functional group within a single molecule, effectively rearranging the molecular structure. DNA recombinase facilitates the exchange of DNA strands between two segments that share partial sequence homology.

Q173 Text Solution:

- A. True – Auxins can induce parthenocarpy (formation of seedless fruits).
- B. True – Plant growth regulators can be involved in promotion as well as inhibition of growth.
- C. True – Dedifferentiation is necessary before a cell can re-differentiate.
- D. Incorrect – Abscisic acid (ABA) is a growth inhibitor, not a promoter.
- E. Incorrect – Apical dominance (due to auxin) inhibits lateral bud growth.

Q175 Text Solution:

Frog respire in water by skin (cutaneous respiration) whereas on land the buccal cavity, skin and lungs act as the respiratory organs.

Q176 Text Solution:

In the question the twins given are a boy and a girl. This shows these are developed from two separate fertilized eggs i.e each have individual sperm and ovum. This type of twins are fraternal twins or dizygotic twins.

Q177 Text Solution:

- A. *Aspergillus niger* – Used industrially for citric acid production, not for household products
- B. *Lactobacillus* – Used in curd formation
- C. *Trichoderma polysporum* – Produces immunosuppressive drug (Cyclosporin A), not used in household products
- D. *Saccharomyces cerevisiae* – Used in baking and alcohol fermentation
- E. *Propionibacterium sharmanii* – Used in Swiss cheese production

So, A and C are NOT involved in household product preparation.

Q178 Text Solution:

Progesterone is secreted from corpus luteum.

Relaxin is secreted from the ovary.

Melanocyte stimulating hormone is secreted from Pars intermedia.

The adrenal medulla secretes two hormones called adrenaline or epinephrine and noradrenaline or norepinephrine. These are commonly called as catecholamines.

Q179 Text Solution:

Selectable markers have been developed which differentiate recombinants from non-recombinants on the basis of their ability to produce colour in the presence of a chromogenic

Presence of insert results into insertional inactivation of the β -galactosidase gene and the colonies do not produce any colour, these are identified as recombinant colonies.

Q180 Text Solution:

$$\frac{dN}{dt} = rN \left(\frac{K-N}{K} \right)$$

This is the Verhulst-Pearl Logistic Growth equation, where:

- N = population size
- r = intrinsic rate of natural increase
- K = carrying capacity
- $\frac{dN}{dt}$ = rate of change in population size

It describes population growth that slows as the population reaches the carrying capacity (K).



NEET JAISI GUIDANCE

AB MILEGI MBBS MEIN BHI
PW MedEd KE SAATH!

Download the PW
MedEd App Now !



GET IT ON
 Google Play

Download on the
 App Store